

**C22- PENDANT INTERFACE CARD
Rev. 4.3**

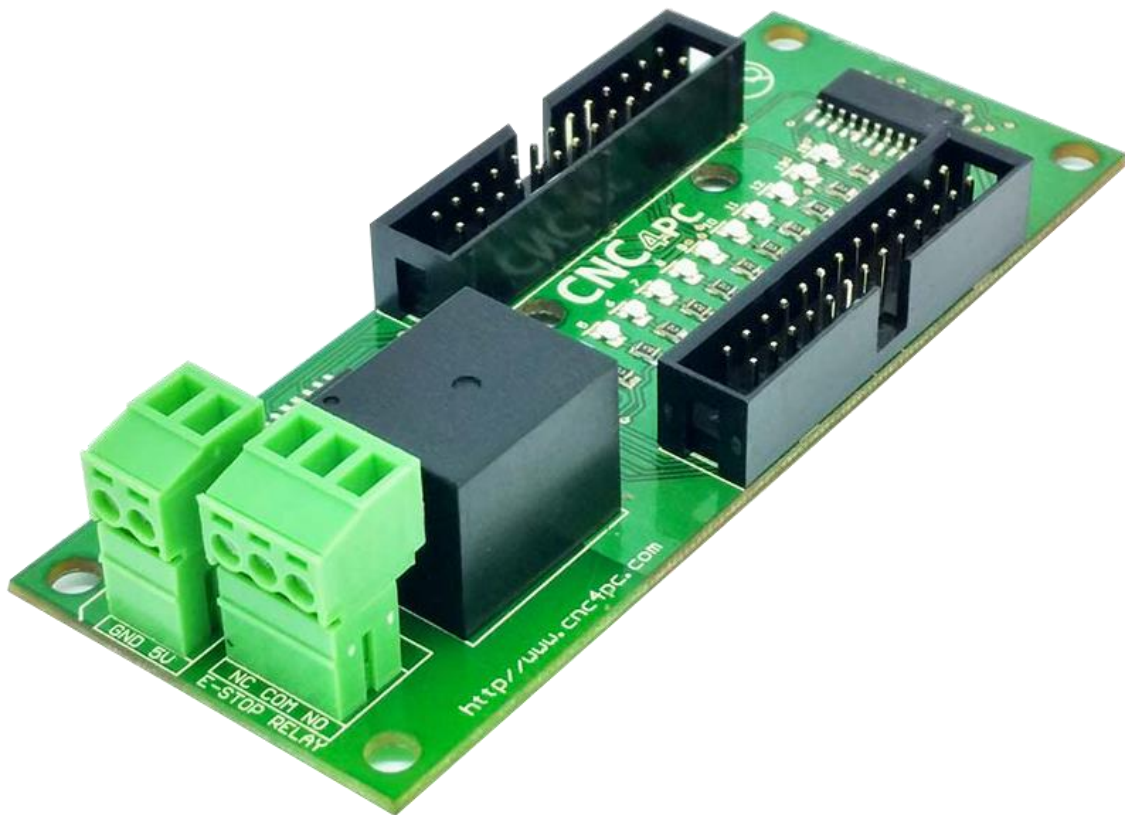

MARCH 2018

USER'S MANUAL

TABLE OF CONTENTS

Contents	<u>Page #</u>
1.0 OVERVIEW.....	1
2.0 FEATURES.....	1
3.0 BOARD DESCRIPTION.....	1
4.0 SPECIFICATIONS	2
4.1 Power Requirements	2
5.0 TERMINAL OF RELAY.....	2
6.0 CONNECTOR IDC26 FOR PENDANT.....	3
7.0 PINOUT PENDANT.....	4
8.0 DIMENSIONS.....	5

1.0 OVERVIEW

This board serves as an interface board for the pendants provided by CNC4PC (MPG2, MPG3, and MPG4). The board conditions the signals (buffer) and provides power to the pendant. The board also has a relay that reflects the status of the e-stop button on the pendant so hardware e-stop functions can be implemented.

2.0 FEATURES

- Connects 4 and 6 axis pendants (MPG2, MPG3, and MPG4)
- Has a relay that reflects the status of the e-stop button.
- Din rail mountable. ***NEW***.
- Pluggable Screw-On Terminals. ***NEW***.
- Status LEDs on all signal connections. ***NEW***.

This relay can be used to enable/disable external devices, such as breakout boards, contactors, etc...

3.0 BOARD DESCRIPTION

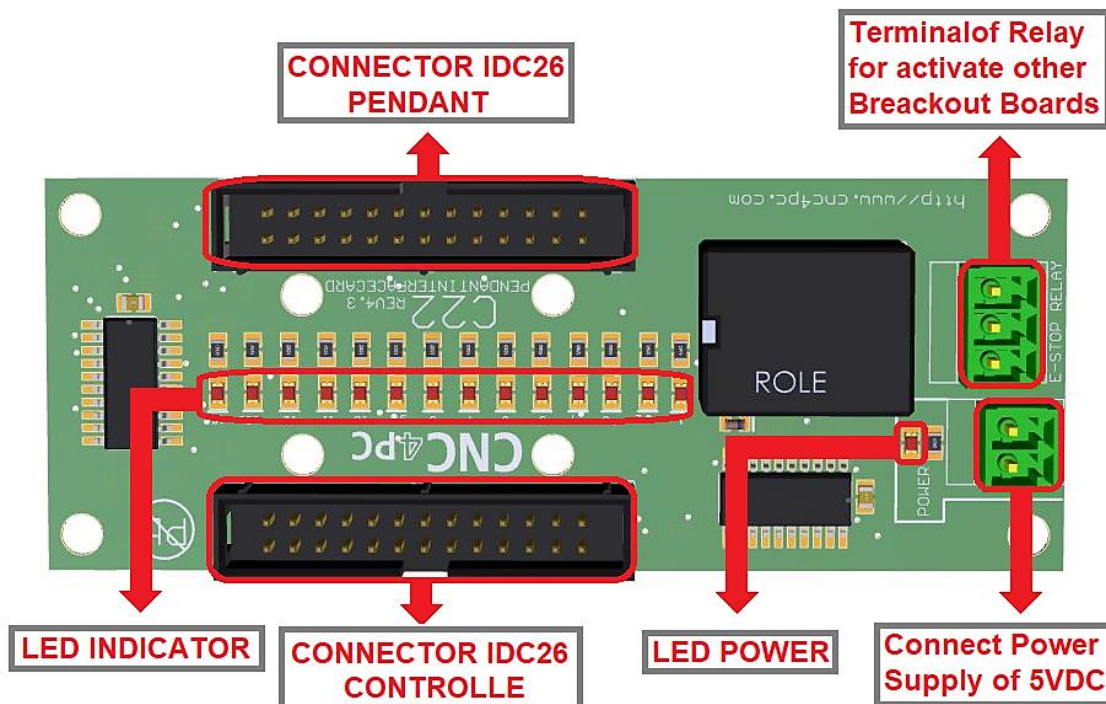

4.0 SPECIFICATIONS

4.1 Power Requirements

Regulated +5VDC@ 200mA is required to power this board.



WARNING

Check the polarity and voltage of the external power source and connect the 5VDC and GND. Overvoltage or reverse-polarity power applied to these terminals can cause damage to the board, and/or the power source.

5.0 TERMINAL OF RELAY

The relay reflects the status of e-stop button on the pendant. The e-stop button is normally closed, when the button is not depressed the circuit is closed and the relay is activated. That activation can be used to keep other hardware active, such as breakout boards, contactors, or an arrangement of relay switches that can govern the safety of the system.

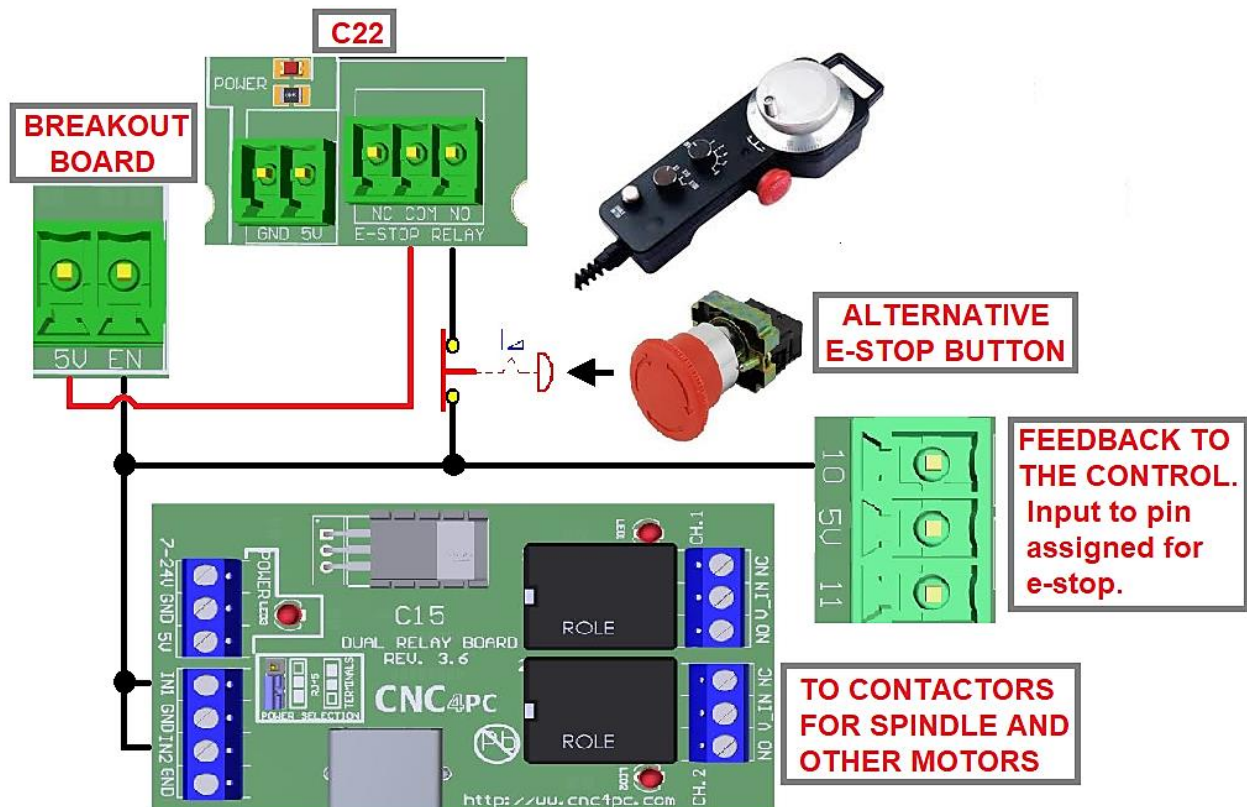

6.0 CONNECTOR IDC26 FOR PENDANT

The board comes with a connector that receives the pendant. A brain file that runs the brain is provided. Please note that the brain file is different from the brain file provided for other expansion boards, since the one is configured to the wiring of this board.

The idea is that you should not use and the PC as a means of deactivating the system in the event of an emergency. The board has a relay can be used as a means to activate/deactivate hardware in a direct manner.

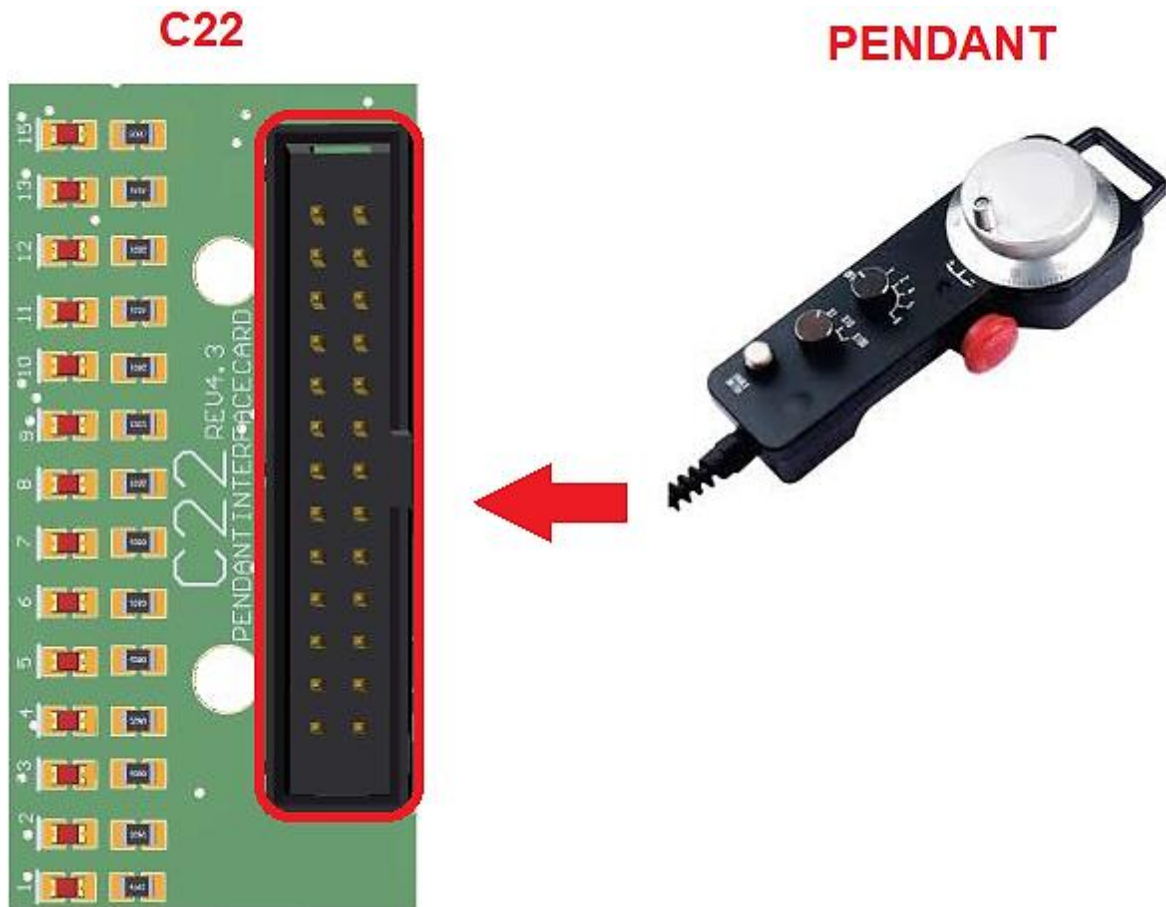

7.0 PINOUT PENDANT

DB26 PENDANT	Color	Function	PC DB25 CONECTOR	MACH3 FUNCTION
1	Red	+5V MPG		
2	Black	GND MPG		
3	Green	A signal MPG	2	MPG1-A
4	White	B Signal MPG	3	MPG1-B
20	purple	A' (when line drive circuit output available)		
21	Purple/black	B' (when line drive circuit output available)		
5	Green/black	+5V LED +	1	
6	White/black	GND LED		
7	Yellow	X Axis select	4	OEM Trig #1
8	Yellow/black	Y Axis select	5	OEM Trig #2
9	Brown	Z Axis select	6	OEM Trig #3
10	Brown/black	4 Axis select	7	OEM Trig #4
18	Pink	5(when select the 5th axis)	12	OEM Trig #9
19	Pink/black	6(when select the 6th axis)	13	OEM Trig #10
11	Gray	X 1 Select	8	OEM Trig #5
12	Gray/black	X10 Select	9	OEM Trig #6
13	Orange	X100 Select	10	OEM Trig #7
14	Orange/black	COM of scale select, and Axis select		
15	Light blue	E stop C	15	OEM Trig #8
16	Light Blue/black	E stop CN		
17	Red/black	N.C, reserve for future use	11	
Shield		Shield wire		

8.0 DIMENSIONS

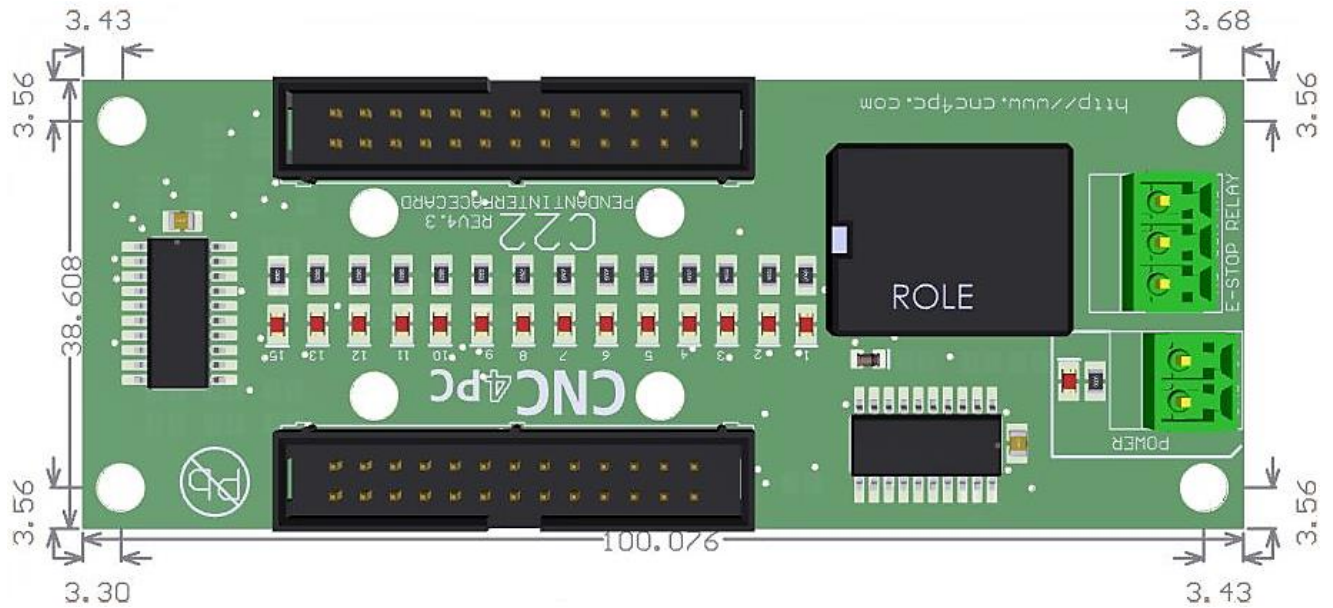

All dimensions are in Millimeters
Fixing holes (4mm).

DISCLAIMER:

Use caution. CNC machines can be dangerous machines. Neither DUNCAN USA, LLC nor Arturo Duncan are liable for any accidents resulting from the improper use of these devices. This board is not a fail-safe device and it should not be used in life support systems or in other devices where their failure or possible erratic operation could cause property damage, bodily injury or loss of life.