

## AGELKOM CAP04 Plasma and Oxy Fuel Torch height control for sheet metal cutting machines Height Sensor & Controller

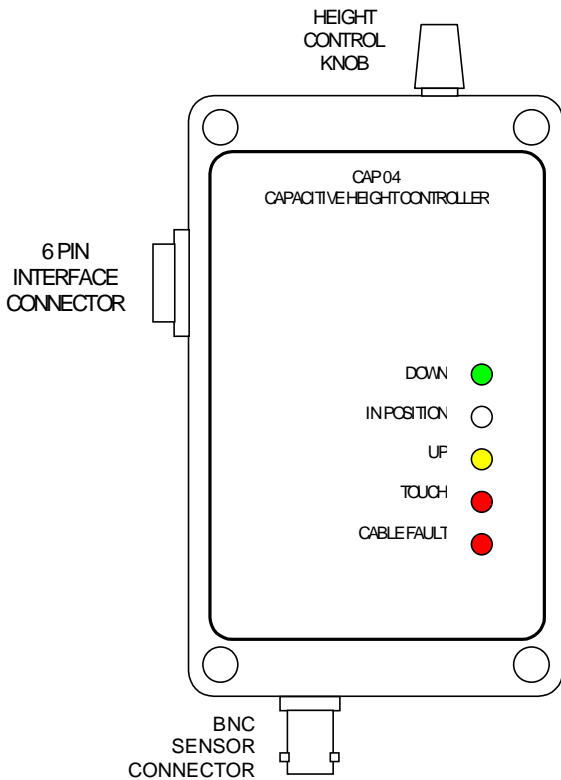

### Description: SENSOR RING:

The metal sensor ring is connected to the CAP04 via a 90 cm long 75 ohms low capacitance coaxial cable. There is a 2 size for Sensor Ring. The Plasma Ring ID is 34 mm and OD is 47 mm. Sensing height of the ring should be between 1,5 to 10 mm above the plate. The Fuel Ring ID is 50 mm and OD is 69 mm. Sensing height of the oxy ring should be between 7 to 35 mm above the plate. The ring must be insulated from all conductive parts of the cutting torch.

### ELECTRONICS:

The connection of supply and outputs to the CAP04 is via 6 core screened cable. Connector can accept cable up to 6.5 mm OD diameter. The supply is nominal 24VDC and the consumption current is less than 150mA.

Do not use same power supply with motors.

The all outputs are at normally low, 15V level during in active and drive up to 15mA.. These outputs can directly drive LED or Opto Coupler. Touch output can be adjusted internal trimpot as a minimum height. It allows NULLING the height, if such feature required.

### GROUNDING:

The diecast box must be grounded. Usually the sensor is bolted to the housing of torch lifter and must be connected via thick wire 50mm<sup>2</sup> from Ground Rods and Plasma Generator to System Ground, the other ones may 25 mm<sup>2</sup> to have a sufficient ground connection. Use STAR type grounding.

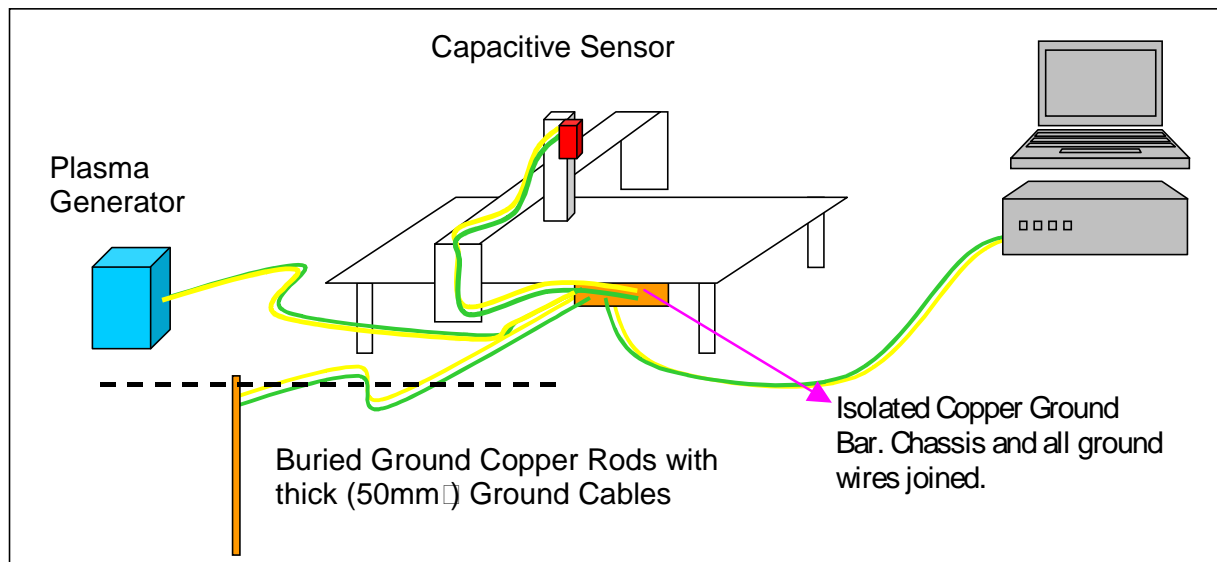

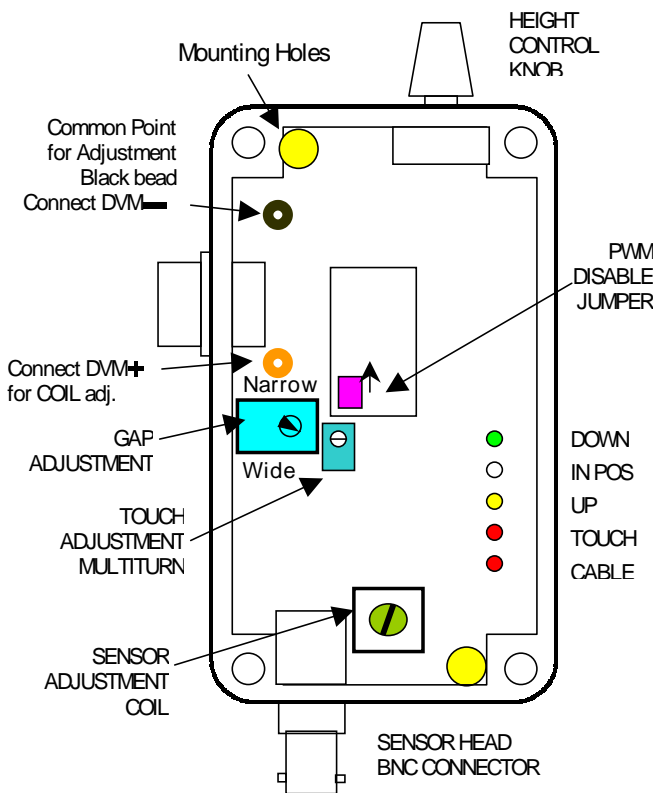

#### ADJUSTMENT:

1. Set  Height Control Knob  to middle position. Manually adjust the torch lifter, so the ring is about 50 mm above the plate.
2. Disable the drive system (e.g. electrically or mechanically disconnect motor).
3. Activate CAP04 and monitor up and down output. At this point DOWN LED must be on, if not internal coil adjustment needed. (Refer Internal Coil Adjustment Section).
4. Decrease the distance between sensing ring and plate and verify that UP LED is ON.
5. Disconnect BNC connector and verify that CABLE LED is ON. Touch with metal part of screwdriver to sensor ring and observe that the TOUCH LED is on.
6. Reconnect the drive system.

The correctly adjusted sensor should activate outputs within +/- 0.05 mm at 1.5 mm above the plate and up to +/- 0.2 mm at 35 mm. with two sensor.

#### Internal Coil Adjustment: (if necessary)

1. Turn adjustment potentiometer (KNOB) fully CCW.
2. In Home position of your Z axis DOWN LED must be ON, if not: Remove the front panel. Use plastic screw driver. Gently adjust, do not more than +/- 1mm turn of the internal coil of CAP04 and observe, DOWN LED is ON in your HOME position (or sufficiently high above the plate). If it is not, readjust the core.
3. Start slowly to decrease the distance between sensing ring and the plate to the cutting height of say 3mm and verify that UP OUTPUT LED is ON. If not, readjust the coil.
4. If you change the cable between the unit to sensor ring, internal coil should be re-adjusted. You can use 70 cm to 100 cm long sensor cable. The original cable length is 90 cm

#### Important:

Factory adjusted. Do not adjust if it is not necessary. It is not SENSITIVITY adjustment Also look adjustment diagram, page 6.

#### Window Adjustment:

There is small amount of GAP (window) between UP and DOWN. Also GAP could be adjusted with internal trimpot. Turning CW of trimpot makes gap wider. Increased cutting height will result in a wider the GAP.

### Touch (Down Limit) Adjustment:

After all adjustment was finished, you can start to adjust Down Limit potentiometer, adjust this multiturn potentiometer until the TOUCH LED turns on. To do this, close the sensor ring until it touches the plate or insert paper between sensor ring and plate (cutting material).

### APPLICATION:

During plasma cutting, sensor ring and plasma torch are in the same height. This will allow to use TOUCH output as a collision detection means. If any error occurs, the UP output activate automatically.

During thick plate cutting, dross may touch the sensor ring and the torch head lifted. To avoid this situation correct your cutting parameters for less dross.

CAP04 can be used with voltage controlled Height Control System. The two systems are ORed.

### POWER / SIGNAL INTERFACE CABLE CONNECTION

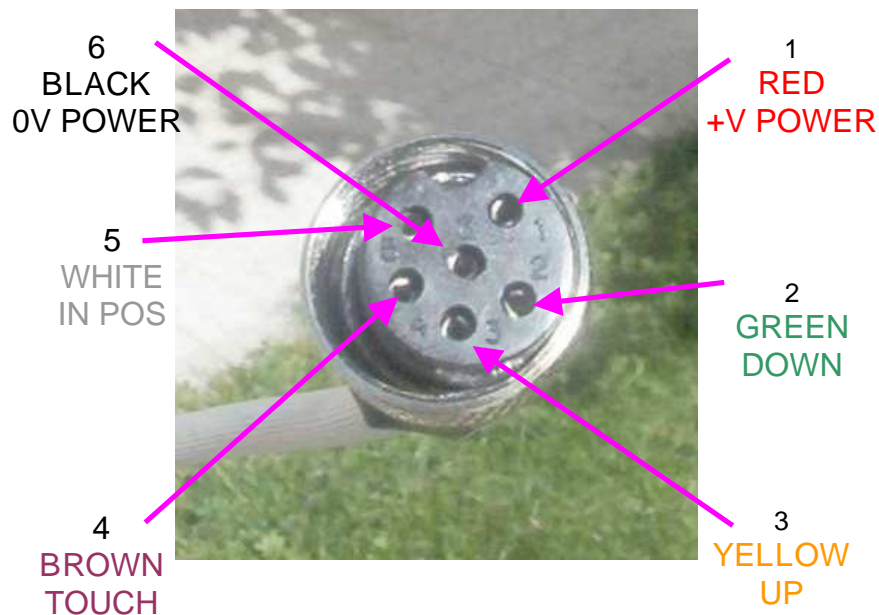

AGELKOM CAPACITIVE SENSOR CAP04	1	CABLE COLORS PINK + 24v
	2	GREEN DOWN
	3	YELLOW UP
	4	BROWN TOUCH
CONNECTOR PIN NUMBER	5	WHITE IN POSITION
	6	GREY 0V

Connection Diagram:

Only one output are shown. Cap04 outputs are HIGH when activated. For UP, DOWN, TOUCH, CABLE FAULT are at 15V and 15mA.

Check your input and configure for ACTIVE HIGH. Your inputs must be 0V level and Pull Up resistor not used.

If your BREAKOUT BOARD has OPTO COUPLER inputs at 5V level, you can connect directly to Cap04 outputs.

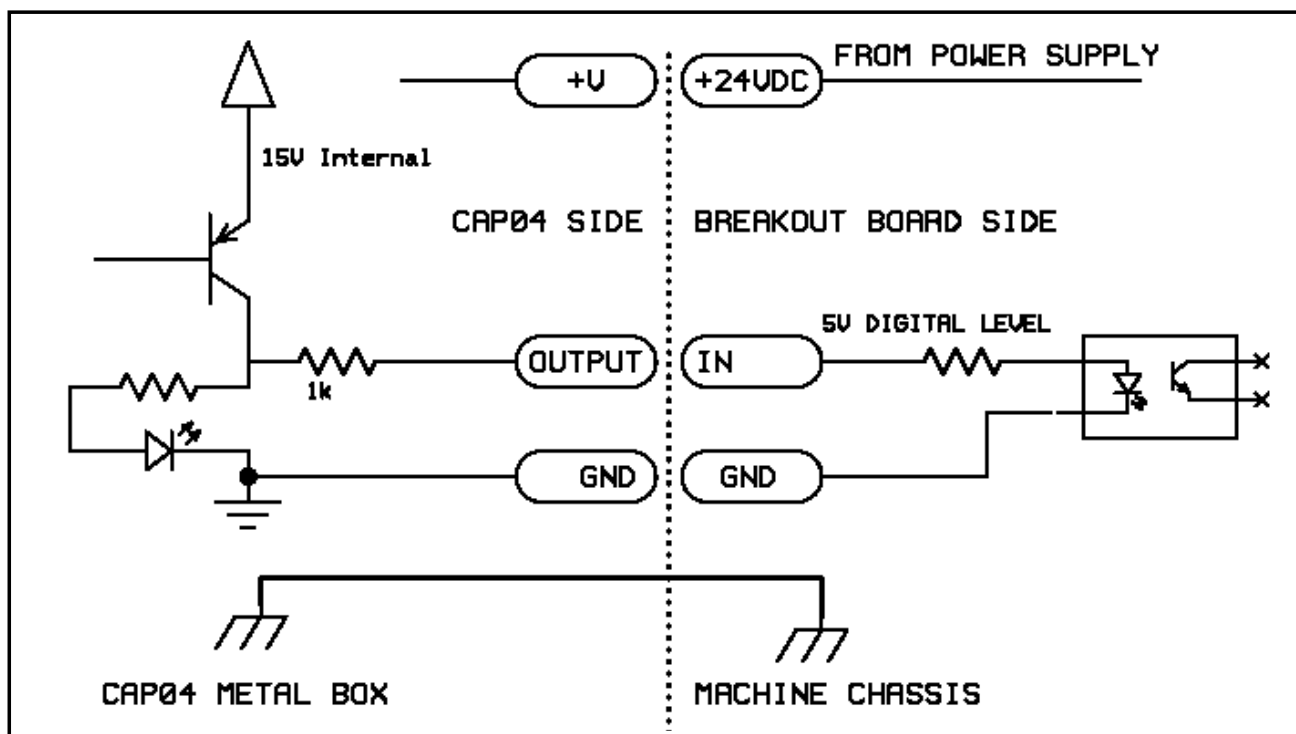

If your BREAKOUT BOARD has 5V digital inputs please use voltage divider resistor as shown below for each inputs.

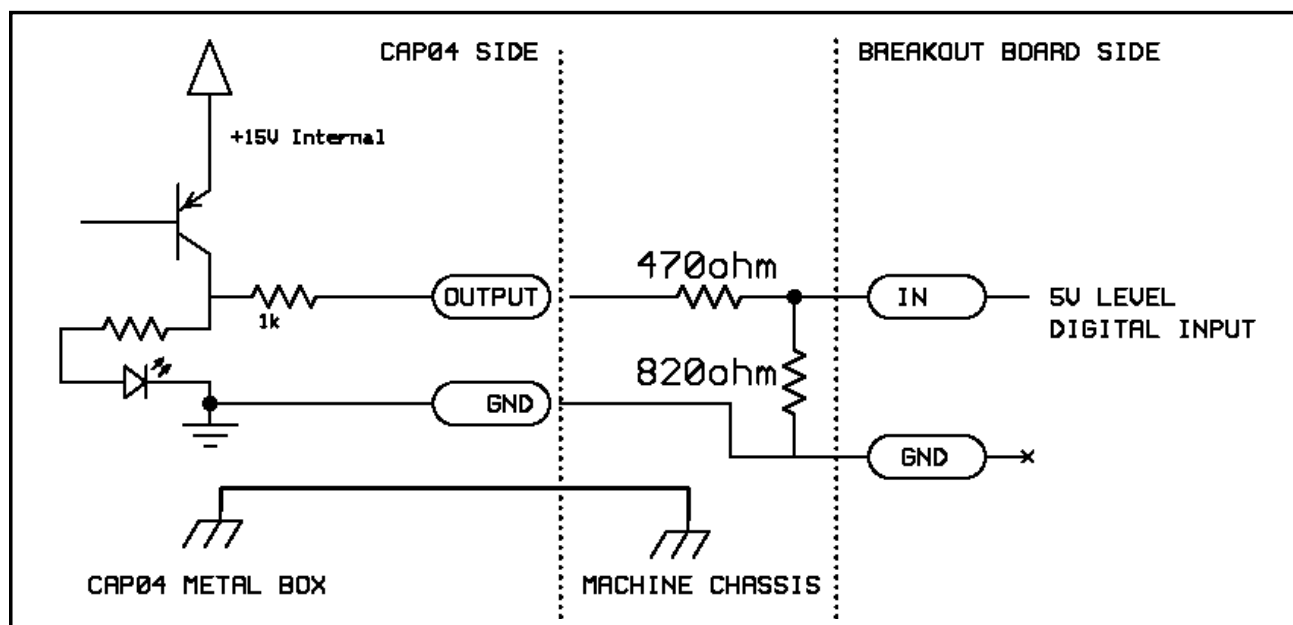

Simplified typical connection of CAP04 sensor is shown below. We advise that using H-Bridge for driving the motor is cost effective. Agelkom H-Bridge-9 Board now available.

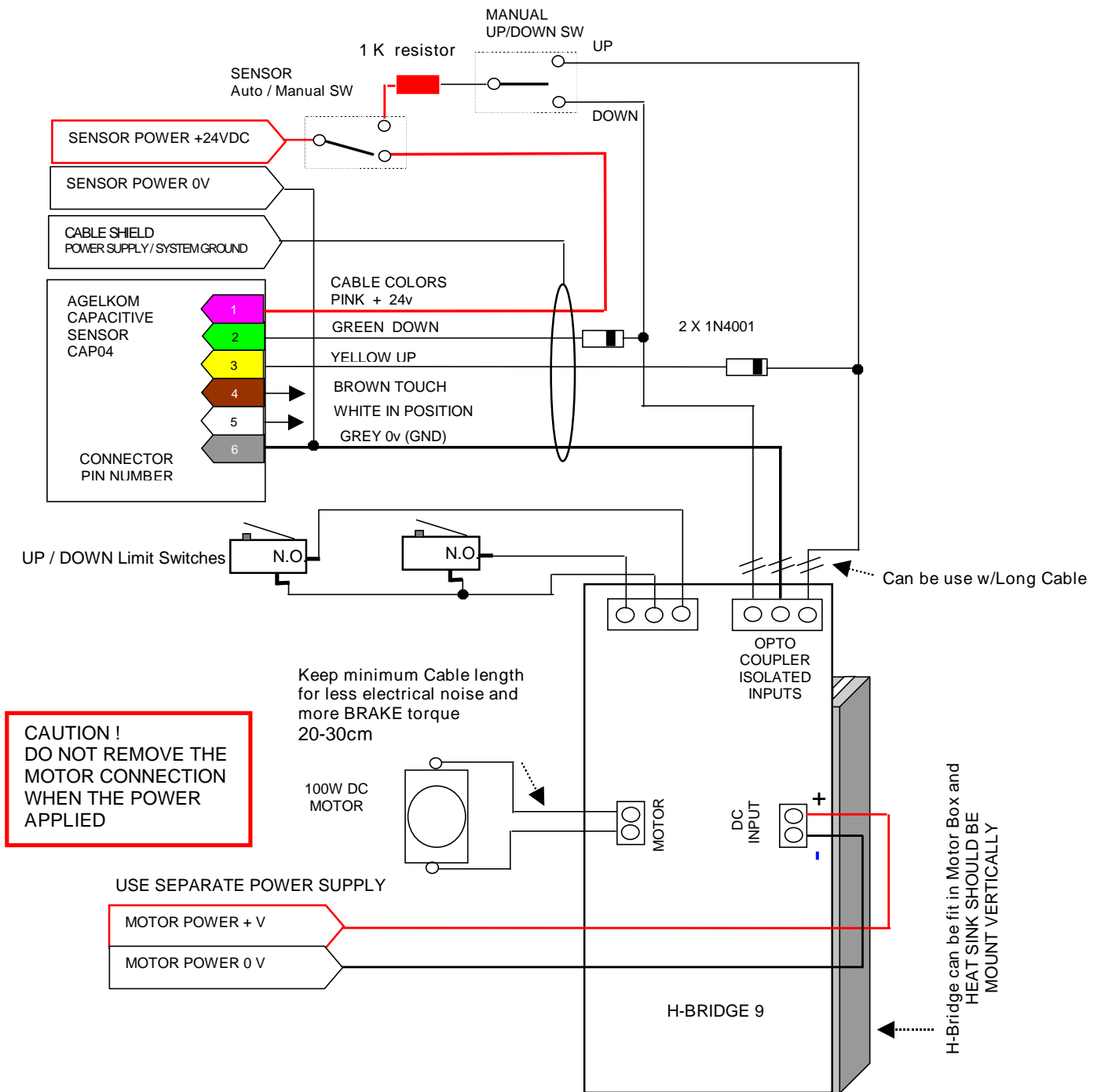

Wiring diagram H-Bridge 9 with BRAKE function

**Internal Coil Adjustment:**

Factory adjusted. Do not adjust if it is not necessary. It is not SENSITIVITY adjustment.

- 1) Mount CAP04 and Sensor Head with Sensor Ring to your machine.
- 2) Keep Sensor Ring to Working Plate distance at maximum (at least 10cm).
- 3) Smoothly close some metal plate (say 20cm x 20cm) to sensor ring and observe that voltage increase (never decrease) come to closer.

**Important:**

Do not turn more than 1/4 turn CW or CCW and do not apply force to the CORE. Use plastic screw driver. If it is not move, use hair dryer in LOW heat. Adjustment can be made within 1mm travel. Never turn fully CW. The CORE is easily broken.

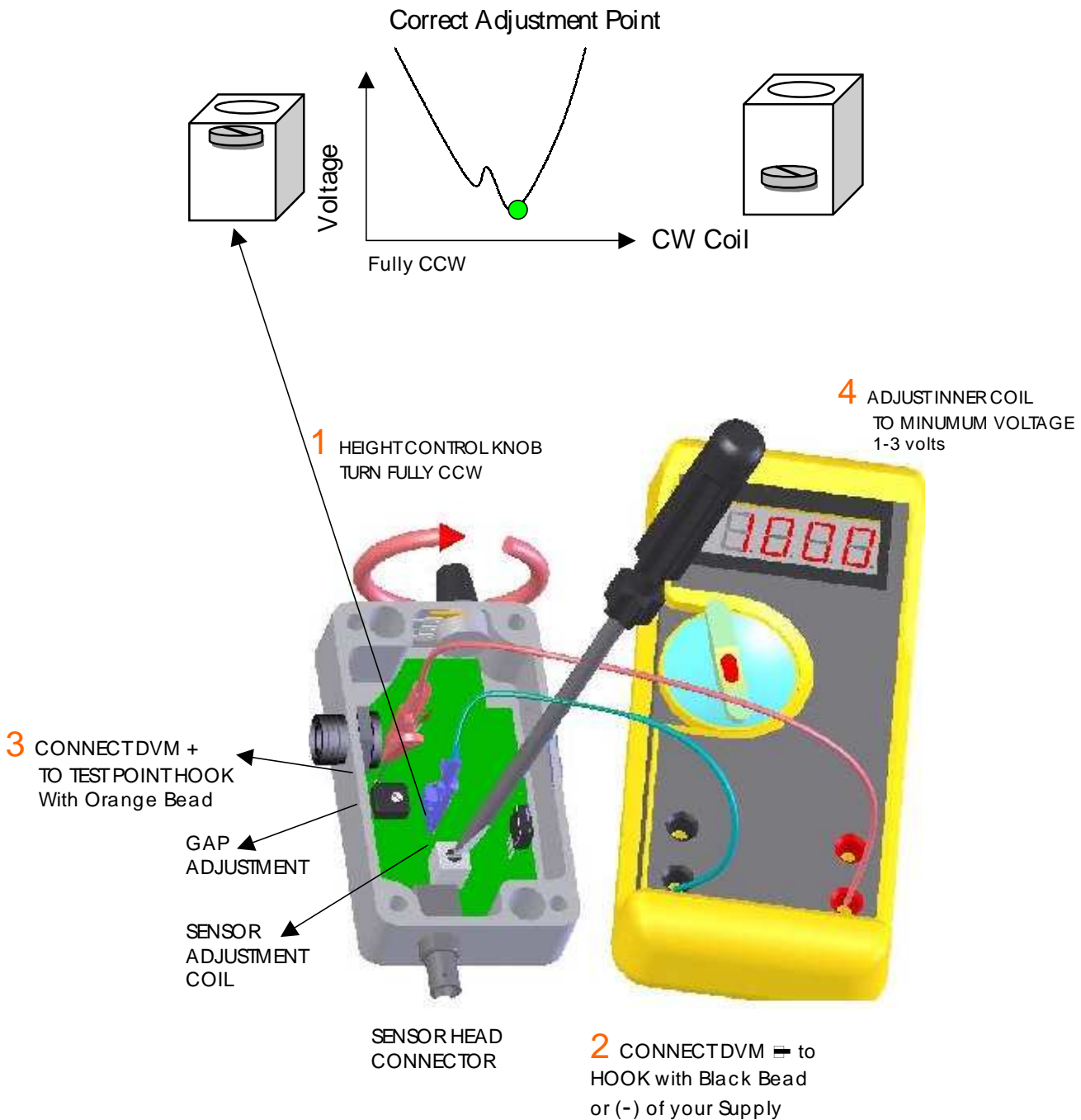

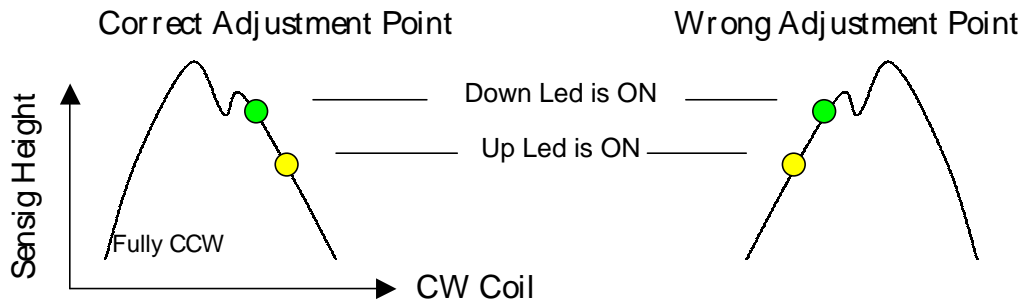

### MOUNTING

Dimensions are in mm. Case Size 116\* 65\* 31

Two mounting holes are shown in red

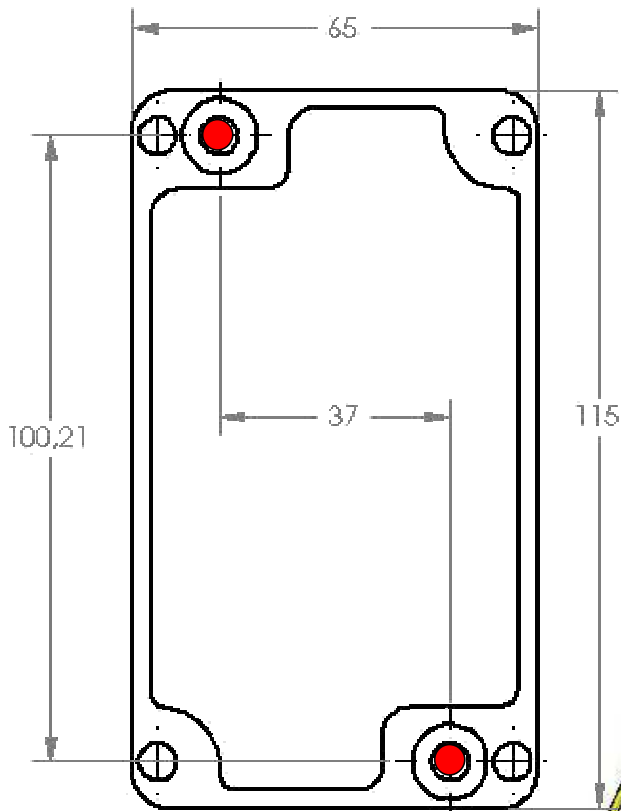

### GROUNDING

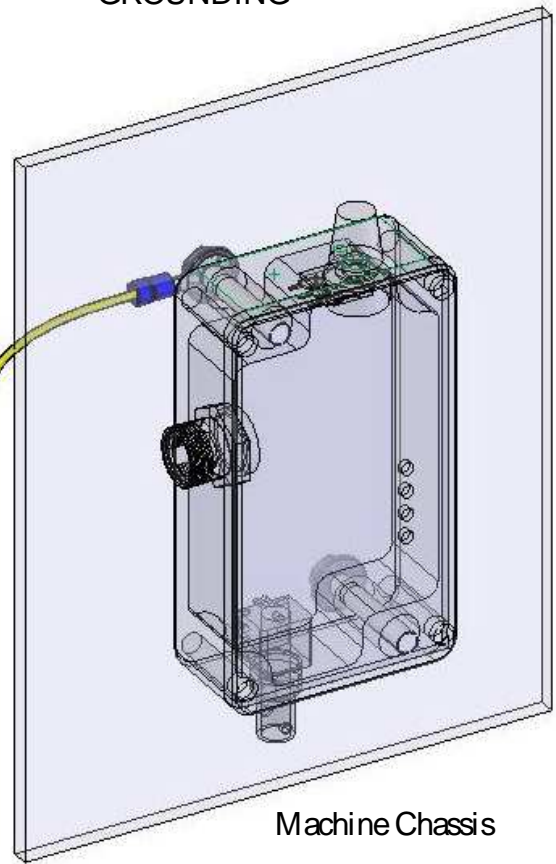

To System & Power Supply Box  
 Use STAR type Ground Connection  
 Use thick wire (10mm<sup>2</sup>)



# Mounting Details

