Datasheet

MX3660

3-Axis Stepper Drive with Breakout Board & I/O's



Version1.0

1. Features

- Power up to 3 stepper motors of NEMA 17, 23, 24, or 34
- Sophisticated stepper motor control based on latest DSP technology
- Built-in breakout board and I/O's
- Step & direction Control
- 20 - 60 VDC supply voltage
- 1.45 - 6.0A output current per axis
- 8 micro step settings: 1, 1/2, 1/4, 1/8, 1/10, 1/16, 1/32, 1/64
- 8 output current settings: 1.45, 2.08, 2.72, 3.37, 4.05, 4.72, 5.35, 6.0 A
- Damping and anti resonance
- Allow individual configurations for each axis
- Input pulse smoothing
- Extra low motor heating & noise
- Extra smooth motor movement
- Simple micro step & output current configuration via DIP switches
- Fault output
- Compact size and easy setup
- 50% automatic idle current reduction

2. Description

The MX3660 is a high performance 3-axis stepper drive with built-in breakout board and I/O's based on the latest DSP technology. It is specially designed for EASY and RAPID control of up to three 2-phase (1.8°) or 4-phase (0.9°) stepper motors in frame sizes NEMA 17, 23, 24, and 34. The MX3660 3-axis stepper drive operates under 20-60 VDC input voltage and can output up to 6.0A current (peak of sinusoidal) per axis. It takes step & direction control and is easy to implement for OEM applications.

By adopting advanced stepper motor control technology, the MX3660 3-axis stepper drive can power stepper motors in high precision, at extra smoothness, and with extra low motor heating & noise. It is featured with anti resonance, multi-stepping, vibration suppression, input command smoothing, 50% idle current reduction, etc.

The MX3660 3-axis stepper drive is easy to configure. Via the 6-pin DIP switch of each of the 3 stepper drive modules, a user can easily set the output current and micro step to one of their 8 available settings, 1.45-6.0A and full step – 1/64 respectively. Each axis can have its own current & micro step configurations to satisfy different requirements for the controlled stepper motor. For example, a user can set axis X at 8 micro step & 6.0A for a NEMA 34 motor, axis Y at 10 micro step & 2.72A to drive a NEMA 23 motor, and axis Z at 16 micro step & 1.45A to for a NEMA 17 motor.

The MX3660 3-axis stepper drive is integrated with a breakout board with a DB25 connector and built-in I/O's. This allows convenient, easy and quick connection for controllers (e.g. PC-based control systems, motion controllers, PLC's...) and external devices (limit switches, VFD...). It simplifies system setup, save installation space & time, minimize wiring, increase reliability, and cut costs. In addition, the MX3660 offers a built-in digital "smoother" to allow filtering/smoothing of "noise" pulses for better system performance (application dependant).

The MX3660 adopts modular designs. If any of the three stepper drive modules malfunctions, a user can simply replace it with a Leadshine SDM660 stepper drive module at minimal cost.

3. Applications

The MX3660 3-axis stepper drive can be easily and rapidly implemented in stepper control systems for OEM applications such as CNC routers / engravers, CNC mills, CNC Cutters, laser cutters / markers / engravers, CNC welders, CNC water jets, X-Y tables, lathes, dispensing machines, medical equipment, scientific instruments...

Its unique design with built-in breakout board and I/O's fits seamlessly in many applications powered by some popular CNC systems such as Mach3, EMC, WinCNC, etc.

4. Specification Summary

<i>Model</i>	MX3660
<i>Axis No.</i>	3
<i>Phase</i>	2 (also works for 4-phase 0.9° stepper motors)
<i>Control Type</i>	Step & Direction
<i>Supply Voltage</i>	20 - 60 VDC
<i>Supply Voltage Type</i>	DC
<i>Suggested power supply voltage</i>	24-54 VDC
<i>Output Current</i>	1.45 - 6.00 A
<i>Max Input Frequency (Per Axis)</i>	200KHz
<i>Micro Step</i>	Full, Half, 1/4, 1/8, 1/10, 1/16, 1/32, 1/64
<i>Output Current (Per Axis)</i>	1.45A, 2.08A, 2.72A, 3.37A, 4.05A, 4.72A, 5.35A, 6.0A
<i>Idle Current Percentage</i>	50%
<i>Logic Current</i>	7-16mA (10mA typical)
<i>Logic Voltage</i>	0-5 VDC
<i>Pulse enabled at</i>	Rising edge
<i># of Digital Inputs</i>	13
<i># of Analog Inputs</i>	1
<i># of Digital Outputs</i>	5
<i>Minimum Step Width</i>	2,500 ns (2.5 microsecond)
<i>Minimum Direction Setup Time</i>	5,000 ns (5 microsecond)
<i>Protection</i>	Over current; over-voltage; emergency protection activated
<i>dimension</i>	162 X 77.5 X 37 mm (6.38 X 3.1 X 1.46 Inch)
<i>Weight</i>	450g (0.99 lb)
<i>Compliance / Certification</i>	RoHS

Electrical Specifications

4.1. Stepper Drive Module

Parameter	Min	Typical	Max	Unit
Input Voltage	20	48	60	VDC
Continuous Current	0	-	6.0(Peak)	A
Pulse Input Frequency	0	-	200	kHz
Pulse Voltage	0	5	5	V
Logic Signal Current	7	10	16	mA
Isolation Resistance	100	-	-	MΩ

4.2. Break out Board

Input Voltage	20-60VDC
ESTOP, Input1, Input2, Input 3, Input 4	Optical Isolation, 12V Source, 10mA MAX
Output 1, Output 2, Output 3, Output 4	Optical Isolation, 24V, 70mA MAX
0-10V Analog Output	0.1 to 8.9V, 20mA MAX

5. Operating Environment

Cooling	Natural Cooling or Forced cooling	
Operating Environment	Environment	Avoid dust, oil fog and corrosive gases
	Ambient Temperature	0°C — 40°C (32 — 104°F)
	Humidity	40 — 90%RH
	Operating Temperature (Heat Sink)	70°C (158°F) Max
Storage Temperature	-20°C — 65°C (-4°F — 149°F)	

6. Mechanical Specifications

Unit: mm (1 inch = 25.4 mm)

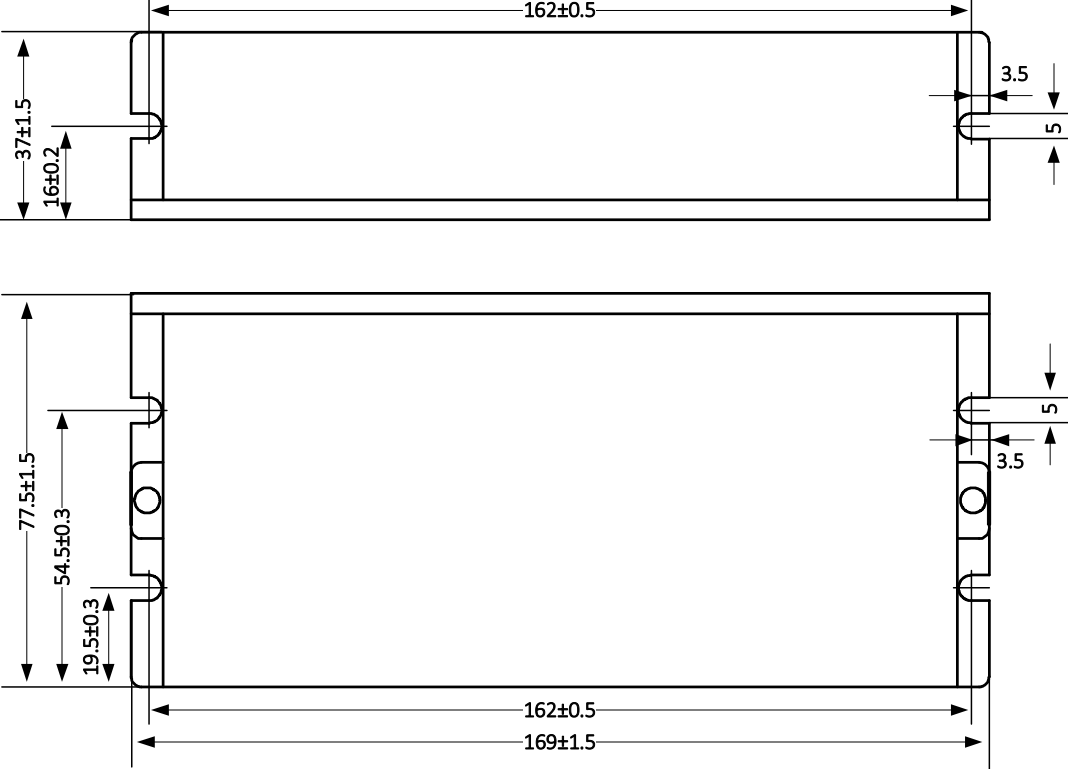

Picture 1 MX3660 connector Location

7. LED Lights

7.1. Led Light Location

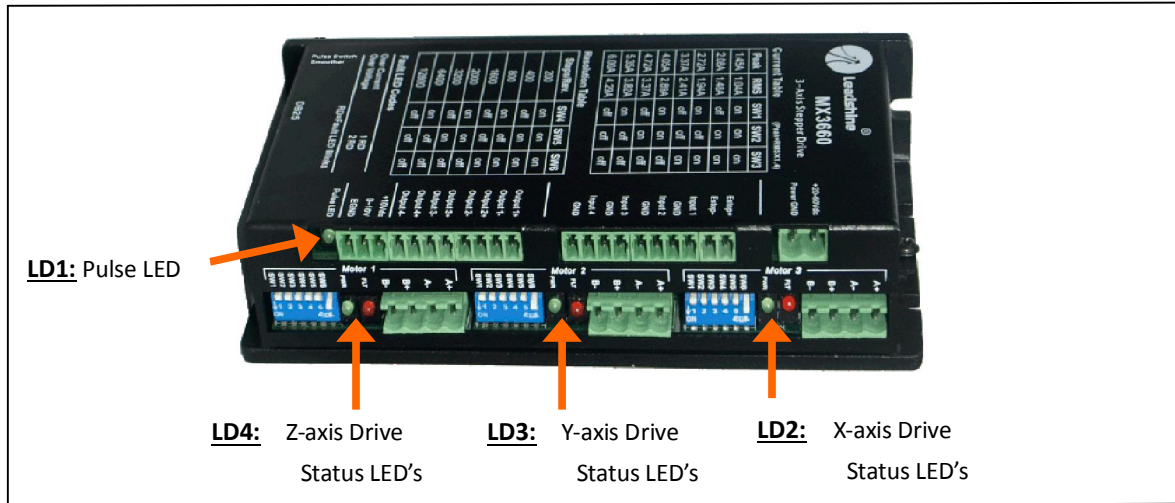

Picture 2 MX3660 LED Lights

7.2. LED Light Indication

7.2.1. LD1 – Pulse LED

This green LED light is specially designed for easy “WORKING STATUS INDICATION” for the connected CNC control system or motion controller. To turn on this LED light, it requires the signal receiving at PIN 16 - “WATCHDOG” - of DB25 connector (picture 3 on page 8). Otherwise, this LED light will be off. For example, in Mach 3 CNC control system, there is a feature called “CHARGE PUMP”. When MX3660 is connected, the green light will be automatically turned on if Mach3 is in working mode and functions properly. Otherwise, this LED light will be turned off and MX3660 will stop working.

7.2.2. LD2 / LD3 / LD4 – Drive Status LED's

There are two LED lights for each stepper drive module (Picture 2), a green one and a red one.

- After a MX3660 3-axis stepper drive is powered on, the green LED light on a drive module should be in solid green and the red LED light off, to indicate that the drive module functions properly.
- If the red LED light of a drive model blinks periodically every 4 seconds, it indicates that protection for that drive module has been activated. In this case, a fault output signal will be outputted from pin 15 of the DB25 connector to notify the motion controller that MX3660 protection has been activated and stopped working. Read Section 10 on page 12 for MX3660 protection.

8. Connectors and Pin Assignments

8.1. Connector Location

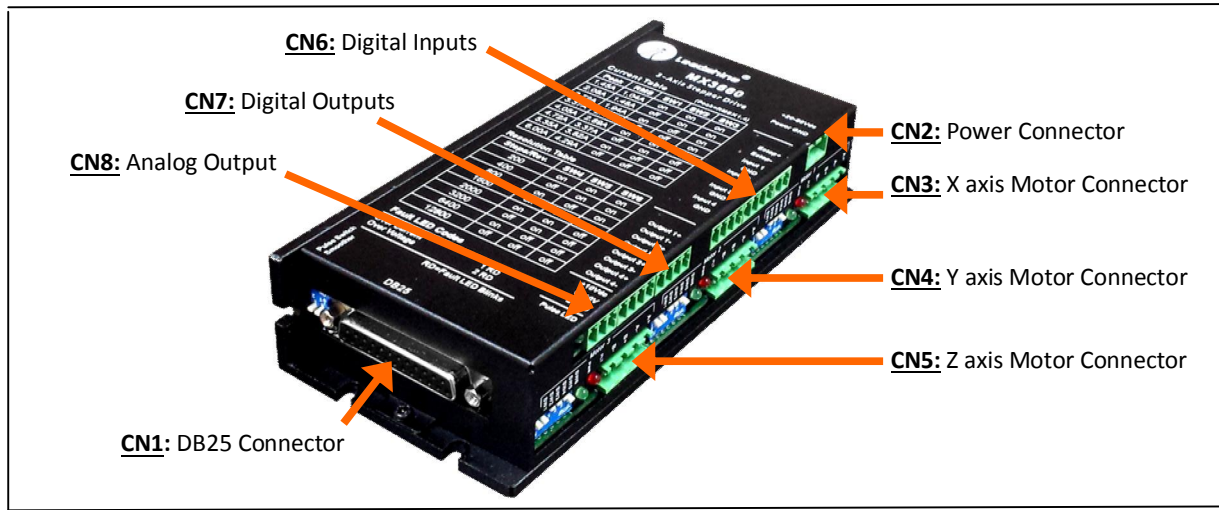

Picture 3 MX3660 connectors

8.2. Connectors and Pin Assignments

8.2.1. CN1 - DB25 Connector

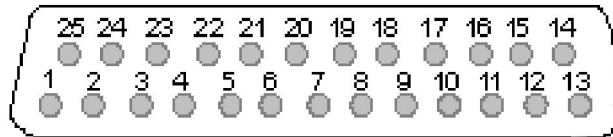

Picture 3 DB25 Connector Pin ordering

Pin	Name	Description
1	INPUT 2	<u>General purpose digital input</u> . It is connected to “Output 2” of the digital output connector (CN7 on picture 2). Used to forward an input signal sent from the connected motion controller to the device connected at “Output 2”.
2	X-AXIS STEP	<u>Input step signal</u> for the X-axis stepper drive board.
3	X-AXIS DIRECTION	<u>Input direction signal</u> for the X-axis stepper drive board.
4	Y-AXIS STEP	<u>Input step signal</u> for the Y-axis stepper drive board.
5	Y-AXIS DIRECTION	<u>Input direction signal</u> for the Y-axis stepper drive board.
6	Z-AXIS STEP	<u>Input step signal</u> for the Z-axis stepper drive board.
7	Z-AXIS DIRECTION	<u>Input direction signal</u> for the Z-axis stepper drive board.
8	INPUT 3	<u>General purpose digital input</u> . It is connected to “Output 3” of the digital output connector (CN7 on picture 2). Used to forward an input signal sent from the connected motion controller to the device connected at “Output 3”.
9	INPUT 4	<u>General purpose digital input</u> . It is connected to “Output 4” of the digital output connector (CN7 on picture 2). Used to forward an input signal sent from the connected motion controller to the device connected at “Output 4”.

8.2.1. CN1 – DB25 Connector (Continued)

Pin	Name	Description
10	OUTPUT 1	<u>General purpose digital output.</u> It is connected to “Input 1” of the digital input connector (CN6 on picture 2). Used to forward an output signal from the device connected at “Input 1”, to the motion controller.
11	OUTPUT 2	<u>General purpose digital output.</u> It is connected to “Input 2” of the digital input connector (CN6 on picture 2). Used to forward an output signal from the device connected at “Input 2”, to the motion controller.
12	OUTPUT 3	<u>General purpose digital output.</u> It is connected to “Input 3” of the digital input connector (CN6 on picture 2). Used to forward an output signal sent from the device connected at “Input 3”, to the motion controller.
13	OUTPUT 4	<u>General purpose digital output.</u> It is connected to “Input 4” of the digital input connector (CN6 on picture 2). Used to forward an output signal sent from the device connected at “Input 4”, to the motion controller.
14	PWM	<u>PWM pulse input.</u> This pin is connected to “+10V” pin of the analog output connector (CN8 on picture 2). It is used to forward a 0-10V analog signal sent from the motion controller to an external device, such as a VFD for spindle speed control.
15	FAULT	<u>Fault signal output</u> back to a motion controller. It will be activated (voltage high) when one of the following events occurs: (1) a signal from ESTOP; (2) any of the 3 built stepper drive modules fails, or is activated for protection.
16	CHARGE PUMP	<u>General digital input.</u> A watchdog timer to enable/disable MX3660. When “Pulse Switch” (picture 4) is set to “OFF” position (Charge pump feature not turned off), the MX3660 will be only enabled with 10KHz signal receiving at this PIN. Otherwise (no such signal received), MX3660 will be disabled. For example, in Mach3 controlled CNC applications, MX3660’s enabling/disabling will depend on the receiving of “Charge Pump” signal from Mach 3.
17	INPUT 1	<u>General purpose digital input.</u> Optical Isolation, 0 - 24V, 70mA MAX. It is connected to “Output 1” of the digital output connector (CN7 on picture 2). Used to forward an input signal sent from the connected motion controller to the device connected at “Output 1”.
18	GND	Ground
19	GND	Ground
20	GND	Ground
21	GND	Ground
22	GND	Ground
23	GND	Ground
24	GND	Ground
25	GND	Ground

8.2.2. CN2 - Power Connector

Name	Description
20-60 VDC	<u>DC Power input</u> for both the MX3660 including the breakout board and three stepper drive drive modules. A 20 - 54 VDC power supply is recommended to leave room for power line voltage fluctuation, and back EMF voltage chargeback during controlled motor deceleration.
Power GND	<u>Power supply ground</u>

8.2.3. CN3 / CN4 / CN5 - Motor Connector

Name	Description
A+	Connection for motor coil phase A+
A-	Connection for motor coil phase A-
B+	Connection for motor coil phase B+
B-	Connection for motor coil phase B-

8.2.4. CN6 - Digital Inputs

Name	Description
Estop+	<u>Emergency stop input</u> (12V Sourcing). When activated, all three drive boards will be shut down and MX3660 will stop working. The red LED of each drive module will blink three times periodically every 4 seconds to indicate an emergency event signal received. In this case, a fault output will be sent to pin 15 - "Fault"- of the DB25 connector to notify the connected motion controller.
Estop-	Common ground
Input 1	<u>General purpose Input</u> (12V sourcing). This pin is connected to pin 10 - "Output 1" - of the DB25 connector. Used to forward the digital output signal, sent from the connected external device here, to the motion controller connected through the DB25 connector.
GND	Common ground
Input 2	<u>General purpose Input</u> (12V sourcing). This pin is connected to pin 10 - "Output 2" - of the DB25 connector. Used to forward the digital output signal, sent from the connected external device here, to the motion controller connected through the DB25 connector.
GND	Common ground
Input 3	<u>General purpose Input</u> (12V sourcing). This pin is connected to pin 10 - "Output 3" - of the DB25 connector. Used to forward the digital output signal, sent from the connected external device here, to the motion controller connected through the DB25 connector.
GND	Common ground
Input 4	<u>General purpose Input</u> (no filtering; 12V Sourcing). This pin is connected to pin 13 - "Output 4" - of the DB25 connector. Used to forward the digital output signal, sent from the connected external device here, to the motion controller connected through the DB25 connector.
GND	Common ground

8.2.5. CN7 - Digital Output

Name	Description
Output 1 +	<u>General purpose output</u> (max 24V@70mA). This pin is connected to pin 17 - "Input 1" - of the DB25 connector. Used to output the digital signal, sent through DB25 "Input 1" from the motion controller, to the connected external device here.
Output 1-	<u>General purpose output</u> - for Output 1
Output 2 +	<u>General purpose output</u> (max 24V@70mA). The pin is connected to pin 1 - "Input 2" - of the DB25 connector. Used to output the digital signal, sent through DB25 "Input 2" from the motion controller, to the connected external device here.
Output 2-	<u>General purpose output</u> - for Output 3
Output 3 +	<u>General purpose output</u> (max 24V@70mA). This pin is connected to pin 8 - "Input 3" - of the DB25 connector. Used to output the digital signal, sent through DB25 "Input 3" from the motion controller, to the connected external device here.
Output 3-	<u>General purpose output</u> - for Output 3
Output4 +	<u>General purpose output</u> (max 24V@70mA). This pin is connected to pint 9 – "Input 4" - of the DB25 connector. Used to output the digital signal, sent through DB25 "Input 4" from the motion controller, to the connected external device here.
Output 4-	<u>General purpose output</u> - for Output 4

8.2.6. CN8- Analog Output

Name	Description
+10V	External +10V power input. Used for power supply connection for the external device (e.g. a VFD) connected at "0-10V" pin.
0-10V	Analog 0-10V output. This pin is connected to Pin 14 f DB25 connector to from pin output. Used to forward the PWM signal, sent from the motion controller, to the connected external device. Read pin 14 – "PWM" – of the DB25 Connector for more information
EGND	External +10V ground

9. Dip Switches

9.1. Dip Switch Location

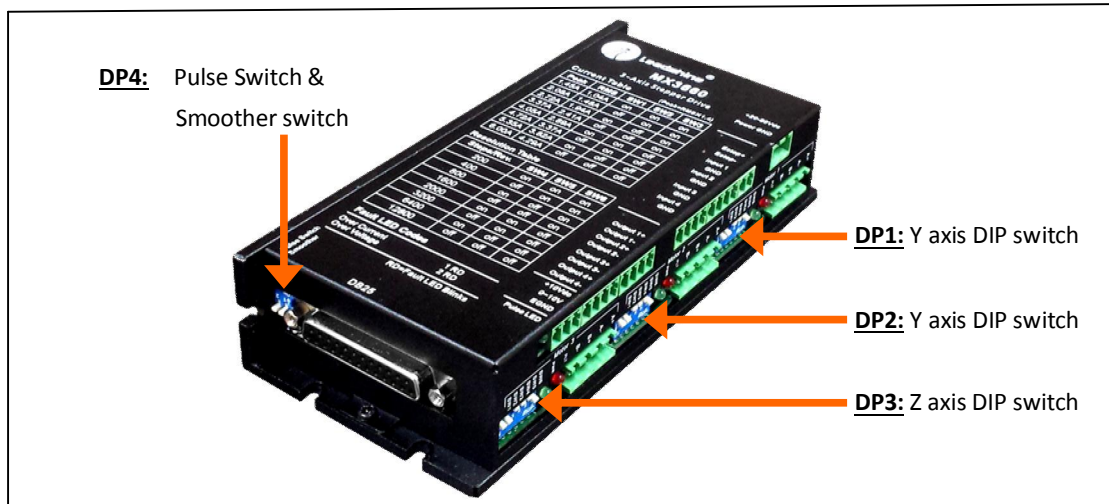

Picture 4 MX3660 connector Location

9.2. Dip Switch Definition

9.2.1. DP1 /DP2 / DP3- X/Y/Z Drive DIP Switch



DP1, DP2, and DP3 are dip switches used to configure micro step resolution and output current configurations of X-axis, Y-axis, and Z-axis drive modules. Read details for their configuration definition in Section 10 on page 12.

9.2.2. DP4 – Pulse Switch & Smoother switch

Pin	Name	Description
1	Smoother Switch	<u>Digital Smoother Switch</u> : This switch is used to enable / disable the MX3660 built-in digital smoother. When an input pulse emulated by the connected motion controller or CNC control system are not in linear or equivalent width, called “noise pulse”, it will cause erratic motion and additional motor/drive noise. Turning on the built-in digital smoother in a MX3660 could potentially (application dependent) improve motion performance. Set this switch to “On” position to enable, and “Off” position to disable the digital smoother.
2	Pulse Switch	<u>Control Source Selector</u> . A switch to enable/disable the “Charge Pump” feature of the MX3660. Read pin 16 description of the DB25 connector (page 8). Set this switch to “ON” position to disable the “Charge Pump” feature and no 10KHz signal receiving verification, before the MX3660 activation. Set it to “OFF” position (means “Charge Pump” is on) to only enable MX3660 with 10KHz signal receiving at PIN 16 of the DB25 connector. For Mach3 controlled systems, set this switch to “Off” position.

10. Protection Indications

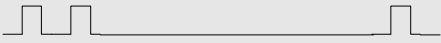
When powered on, the green light of all 3 stepper drive modules will be on and red light off to indicate MX3660 function properly. When protection is activated, the red light of a drive module will blink periodically every 4 seconds to indicate the error type. For each blink, red light lasts for 0.2 second and then off for 0.3 second.

Priority	Time(s) of Blink	Sequence wave of red LED	Description
1st	1		Over-current protection activated
2nd	2		Over-voltage protection activated
3rd	3		Emergency stop activated

11. Drive DIP Switch Settings

11.1. Current Setting (SW1-SW3)

Use pin 1-3 of the DIP switch of a drive module to configure the output current referred in the following table.

Peak	RMS	SW1	SW2	SW3
1.45A	1.04A	on	On	on
2.08A	1.48A	off	On	on
2.72A	1.94A	on	Off	on
3.37A	2.41A	off	Off	on
4.05A	2.89A	on	On	off
4.72A	3.37A	off	On	off
5.35A	3.82A	on	Off	off
6.00A	4.29A	off	Off	off

11.2. Micro Step Resolution Setting (SW4-SW6)

Use pin 4-6 of the DIP switch of a drive module to configure the micro step referred in the following table.

Micro Step	Steps/Rev	SW4	SW5	SW6
Full	200	On	On	On
Half	400	Off	On	On
1 / 4	800	On	Off	On
1 / 8	1600	Off	Off	On
1 / 10	2000	On	On	Off
1 / 16	3200	Off	On	Off
1 / 32	6400	On	Off	Off
1 / 64	12800	Off	Off	Off

12. Typical Connections

When implemented properly, the MX3660 can be used to power three 2 phase (1.8°) or 4 phase(0.9°) stepper motors of NEMA 17, 23, 24, and 34. The following picture illustrates a MX3660 sample connection with 3 stepper motors. External devices through MX3660 I/O connection are optional at a user's choice.

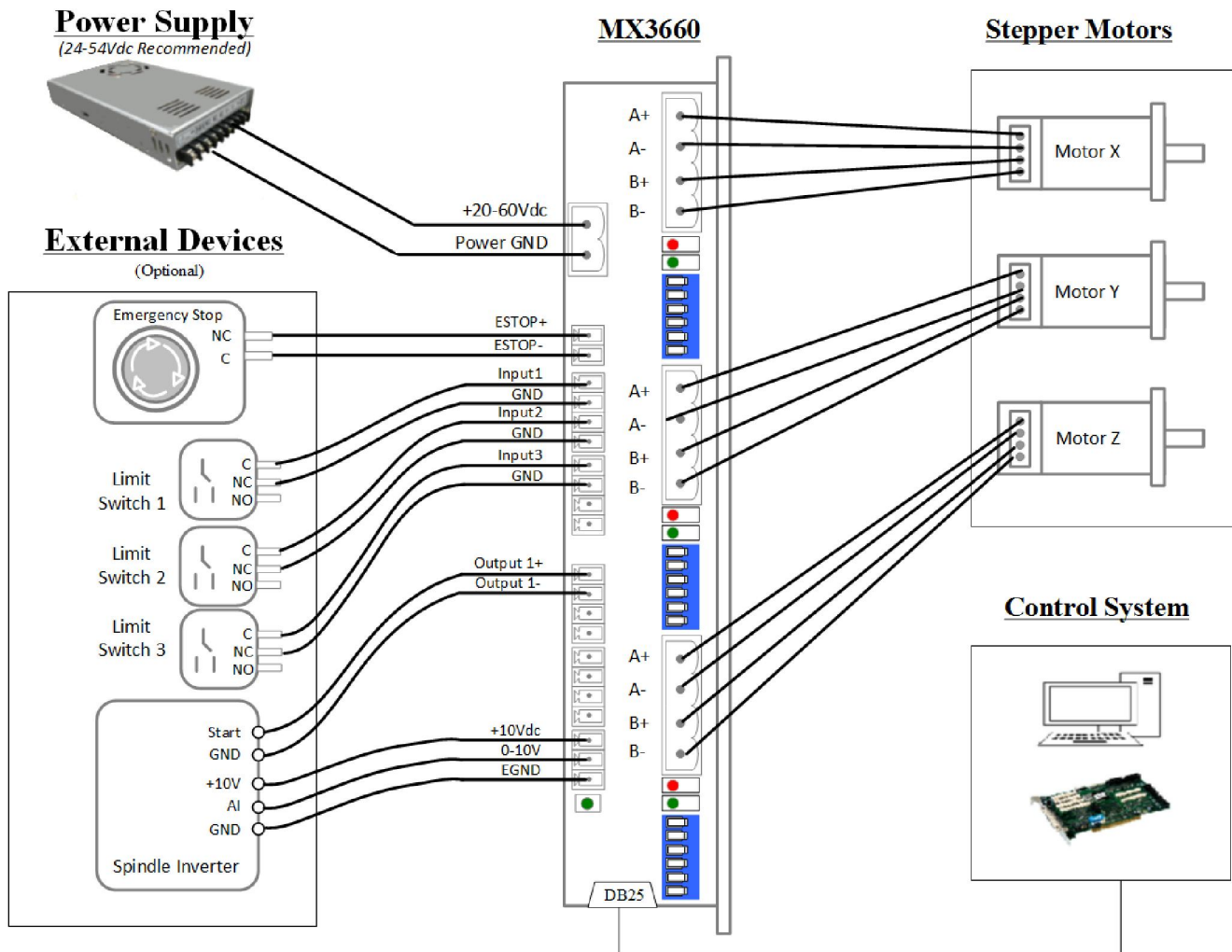

Picture 5 MX3660 Wiring Diagram