

Description

The driver will drive DC brushless motors at currents up to 20A and 36V(45V Max). A constant velocity mode can be selected by using hall sensor feedback. An internal potentiometer is included on the driver to control the speed of the motor. An external voltage of 0-5V can also be used to control the speed. The direction of the motor is specified by direction control input.

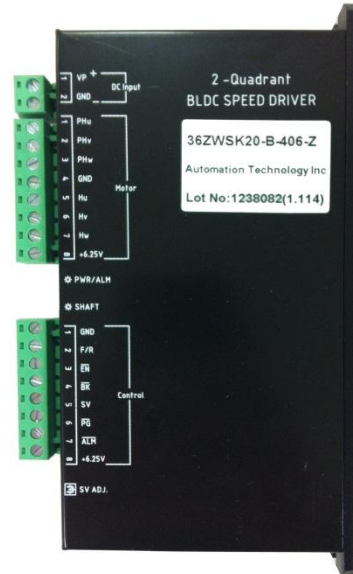

Dimensions

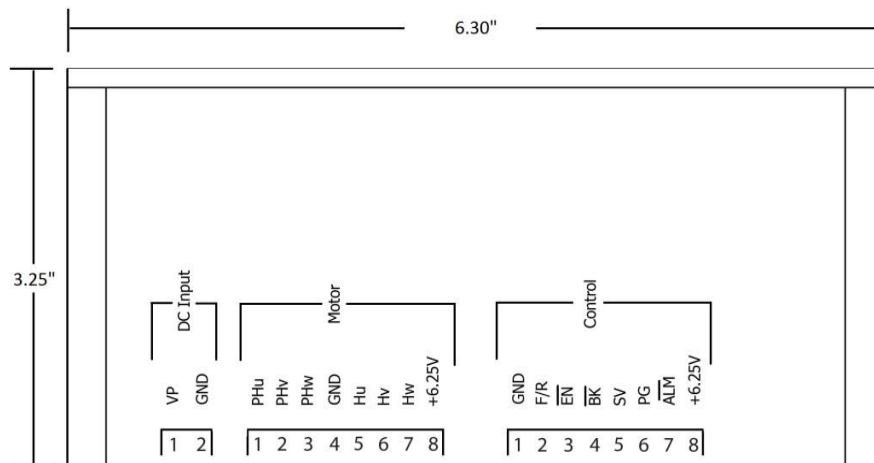

Features

- Short Circuit Protection
- Requires 30-50VDC
- 2-Quadrant Operation
- Multiple Mounting Option
- Both internal or External Potentiometer Control
- Hall Sensor Feedback

2-Quadrant BLDC SPEED DRIVER – Brushless DC Controller

Pinouts

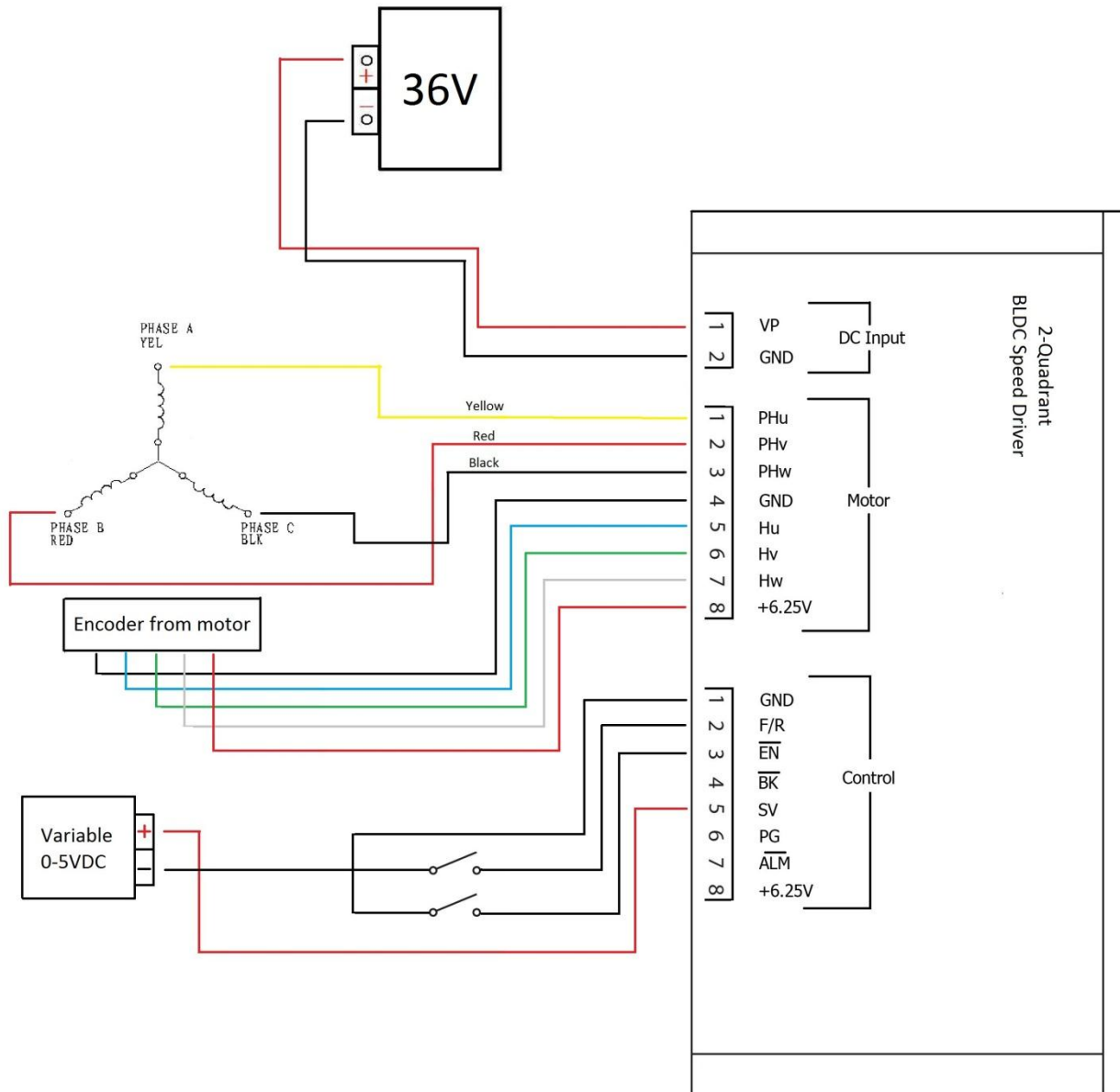

Specifications

Control Inputs

F/R Direction Control (Pin 2):

Logic "1" (open) – Counterclockwise
Logic "0" – Clockwise

Enable (EN) (Pin 3):

Logic "1" (open) – Motor is de-energized
Logic "0" – Motor energized

SV Source Voltage (Pin 4):

Apply +5 Volts

PG (Pin 5):

Active low

ALM Alarm (Pin 6):

Active low

+6.25V

Apply +6.25 Volts