

Datasheet of the High Voltage Easy Servo Drive

ES-DH2306



150-230VAC, 6.0A Peak, Closed-loop, No Tuning

Version 1.2

Features

- I Hybrid servo control technology to combine advantages of open-loop stepper systems and brushless servo systems
- I Closed-loop controls to eliminate lose of steps, stall or movement synchronization
- I High starting torque and quick response
- I Smooth motor movement with no vibration
- I Excellent respond time, quick acceleration, and very high high-speed torque (30% over open-loop)
- I Load-dependent dynamic current output from drive to motor to significantly motor heating deduction
- I Input voltage from 150 to 230 VAC; MAX 6.0A peak current output from drive to motor
- I Micro step resolution value from 200-51,200 (increased by 1) via software configuration
- I Isolated control inputs of Pulse, Direction and Enable
- I No tuning for plug and play setup
- I On-board HMI for easy setup and configuration
- I In-position and fault outputs to external motion controllers for complete system controls.
- I Over voltage, over-current, and position-error protection

Description

By taking direct 110 / 120 or 220 / 230 VAC input, Leadshine ES-DH series high voltage easy servo drives can power large NEMA 34 and 42 easy servo motors and offer huge torque to applications with motion control systems.

Leadshine ES-DH series easy servo drives are based on the latest DSP technology and Leadshine's advanced control algorithm of combing brushless servo and stepper systems. They are featured with closed position loop, offering huge torque, excellent acceleration & quick response, no torque reservation, high standstill stiffness, extra low noise & heating, smooth motor movement, no hunting, no overshooting for almost zero settling time, and no tuning for almost all applications.

Applications

Due to combining the features of both brushless servo drives and stepper drives, Leadshine ES-DH series easy servo drives are suitable for both upgrading conventional stepper systems, and replacing brushless servo systems which have closed loop and high torque requirements.

Leadshine ES-DH series easy servo drives can also be implemented as high performance open loop stepper drives with direct 110 / 120 and / or 220 /230 VAC input.

Leadshine ES-DH easy servo drives and matching easy servo motors have been successfully implemented by many OEM clients in applications such as CNC routers, plasma, milling machines, engravers, packaging machines, printing equipments.

Specifications

Electrical Specifications

Parameters	ES-DH2306
Operating Voltage	150 – 230 VAC
Maximum Continuous Current	6.0 A
MAX Step Frequency	200KHz or 500KHz (Software Configuration)
Step, Direction and Enable Voltage	5 – 24 V
Logic Signal Input Current	7 – 20 mA

Control Specifications

Parameters	ES-DH2306
Command Input	Step/Direction, CW/CCW
Enable/Disable Input	Differential
Alarm Signal Output	Isolated OC Output
Configuration Interface	On-board HMI or RS232 communication
Regeneration Resistor	Built-in (50 Ohm, 100W), Support External

Mechanical Specifications

Parameters	ES-DH2306
Size	180mm * 140mm* 70mm
Weight	1500 g

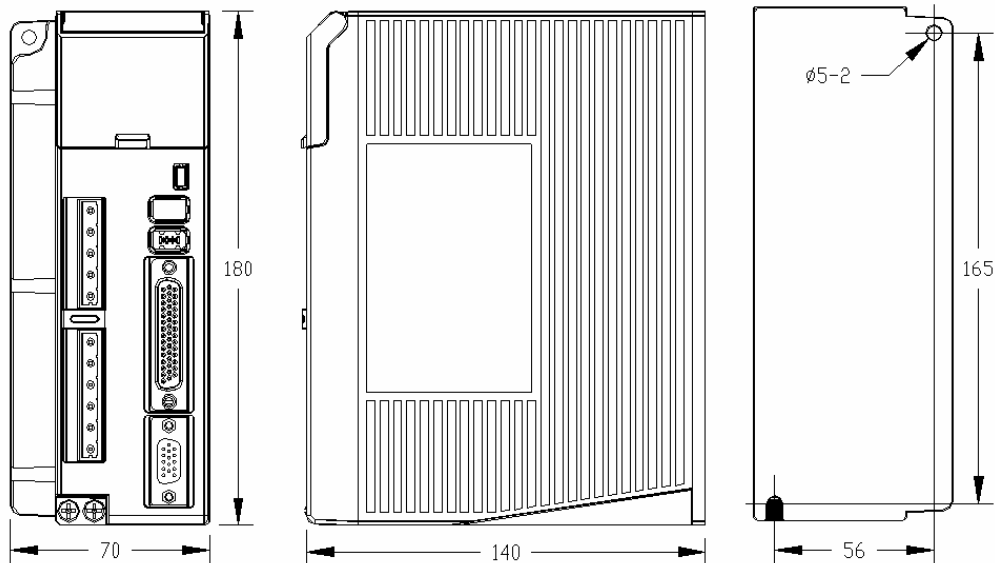

Operating Environment

Cooling	Natural cooling or Forced cooling
Ambient Temperature	0 – 40 °C
Humidity	40% RH to 90% RH, No Condensation
Vibration	5.9 m/s ² MAX
Storage Temperature	-20 °C to 80 °C

Drive Appearance and Interfaces

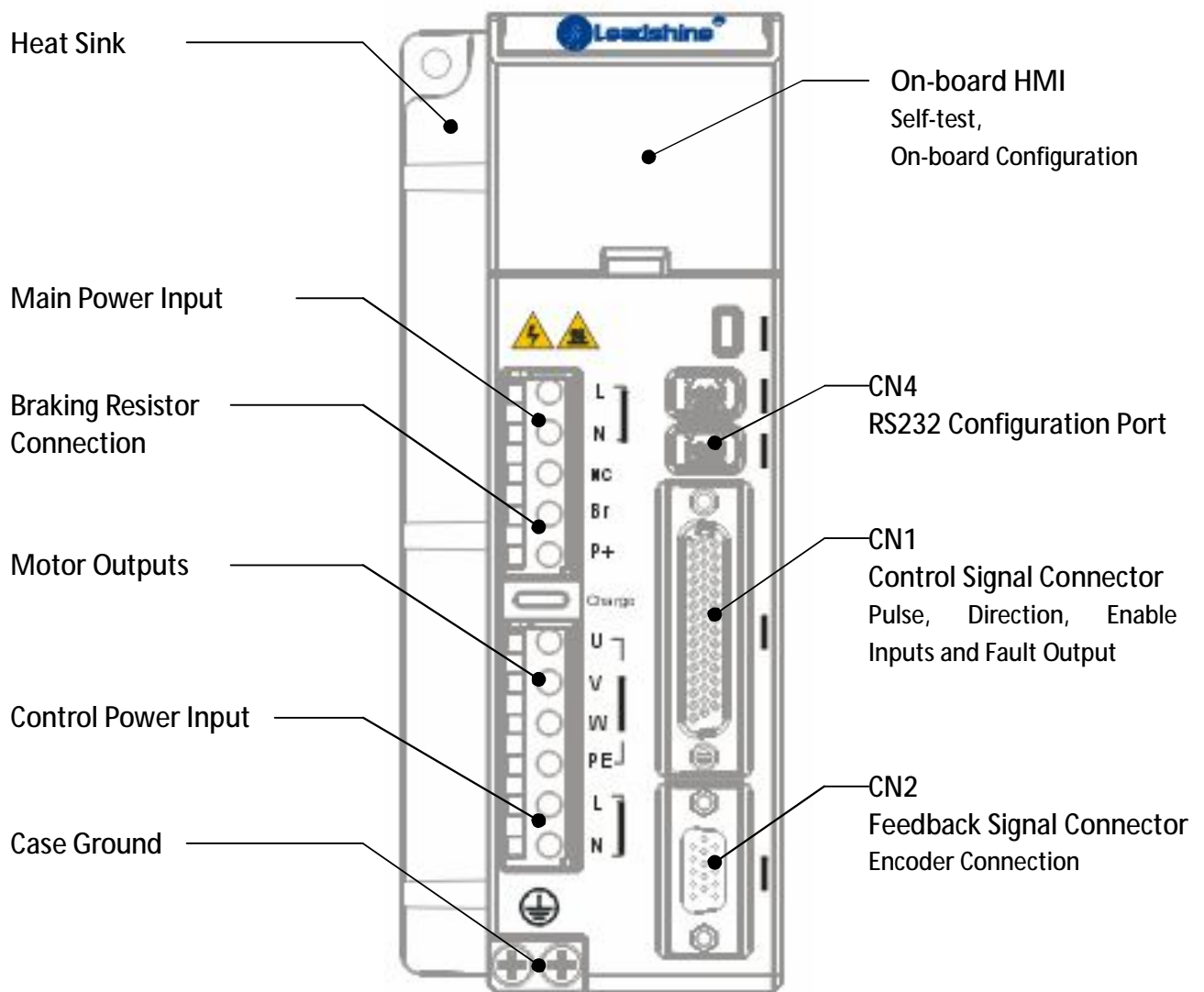

Connectors and Pin Assignments

CN1 – Control Signal Connector			
D-Sub, 26 Pin, Female			
Pin	Name	I/O	Description
1	NC	-	No connection.
2	NC	-	No Connection.
3	PUL+	I	Pulse signal: In single pulse (pulse/direction) mode, this input represents pulse signal, each rising or falling edge active (software configurable); In double pulse mode (software configurable), this input represents clockwise (CW) pulse, active both at high level and low level. 5-24V when PUL-HIGH, 0-0.5V when PUL-LOW. For reliable response, pulse width should be longer than 2.5uS(200K bandwidth) or 1uS(500K bandwidth)
4	PUL-	I	
5	DIR+	I	Direction Signal: In single-pulse mode, this signal has low/high voltage levels, representing two directions of motor rotation. In double-pulse mode (software configurable), this signal is counter-clock (CCW) pulse, active both at high level and low level. For reliable motion response, DIR signal should be ahead of PUL signal by 5μs at least. 5-24V when DIR-HIGH, 0-0.5V when DIR-LOW. The direction signal's polarity is software configurable.
6	DIR-	I	
7	ALM+	O	Alarm Signal: OC (Open Collector) output signal, activated when one of the following protection is activated: over-voltage, over current, braking error and position following error. They can sink or source MAX 100mA current at 5V. The active impedance of alarm signal is software configurable.
8	ALM-	O	
9	NC	-	No connection.
10	NC	-	No connection.
11	ENA+	O	Enable signal: This signal is used for enabling/disabling the driver. By default, high level (NPN control signal) for enabling the driver and low level for disabling the driver. It is usually left UNCONNECTED (ENABLED). Please note that the PNP and Differential control signals are on the contrary, namely Low level for enabling. The active level of ENA signal is software configurable.
12	ENA-	O	
13	NC	-	No connection.
14	NC	-	No connection.
15	NC	-	No connection.
16	NC	-	No connection.
17	NC	-	No connection.
18	NC	-	No connection.
20	NC	-	No connection.
21	NC	-	No connection.
22	NC	-	No connection.

Connectors and Pin Assignments (Continued)

CN1 – Control Signal Connector			
D-Sub, 26 Pin, Female			
Pin	Name	I/O	Description
23	NC	-	No connection.
24	NC	-	No connection.
25	NC	-	No connection.
26	NC	-	No connection.
27	NC	-	No connection.
28	NC	-	No connection.
29	NC	-	No connection.
30	NC	-	No connection.
31	NC	-	No connection.
32	NC	-	No connection.
33	NC	-	No connection.
34	NC	-	No connection.
35	NC	-	No connection.
36	NC	-	No connection.
37	NC	-	No connection.
38	NC	-	No Connection.
39	NC	-	No connection.
40	NC	-	No connection.
41	NC	-	No connection.
42	NC	-	No connection.
43	NC	-	No connection.
44	NC	-	No connection.
	FG	-	Ground Terminal for shield

Connectors and Pin Assignments (Continued)

CN2 – Feedback Signal (Encoder) Connector			
HDD15, 15Pin, Female			
Pin	Name	I/O	Description
1	EA+	I	Encoder A+ input
2	EB+	I	Encoder A- input
3	EGND	I/O	+5V output return ground
4	NC	I	No Connection.
5	NC	I	No Connection.
6	FG	I	Ground terminal for shield
7	NC	I	No Connection
8	NC	I	No Connection
9	NC	I	No Connection.
10	NC	I	No Connection.
11	EA-	I	Encoder A- input
12	EB-	I	Encoder B- input
13	+5V	O	+5V power output for encoder, MAX 100mA.
14	NC	I	No Connection.
15	NC	I	No Connection.

CN4 – RS232 Communication Connector			
RS232		Can be connected to PC for drive configuration or servo tuning. Recommended twisted shielded cable and cable length < 2 meter.	
Pin	Name	I/O	Description
1	GND	GND	Ground.
2	TxD	O	RS232 transmit.
3	+5V	O	Reserved +5V power output (Note: Do not connect it to RS232 port)
4	RxD	O	RS232 receive.
5	NC	-	NC
6	NC	-	NC

Connectors and Pin Assignments (Continued)

Main Power Supply Connector:			
Pin	Name	I/O	Description
1	L	I	Main power supply input connected to 150- 230VAC.
2	N	I	
3	NC	-	
4	BR1	I	External regeneration resistor connection.
5	P+	O	Internal DC bus voltage output. The regeneration resistor should be connected between BR1 and P+.

Motor & Control Power Supply Connector			
Pin	Name	I/O	Description
1	U	O	Motor phase U
2	V	O	Motor phase V
3	W	O	Motor phase W
4	PE	-	Case ground
5	L	I	Control Power Supply from 150VAC to 230VAC.
6	N	I	

Connector Pin-Out

CN1 – Control Signal Connector

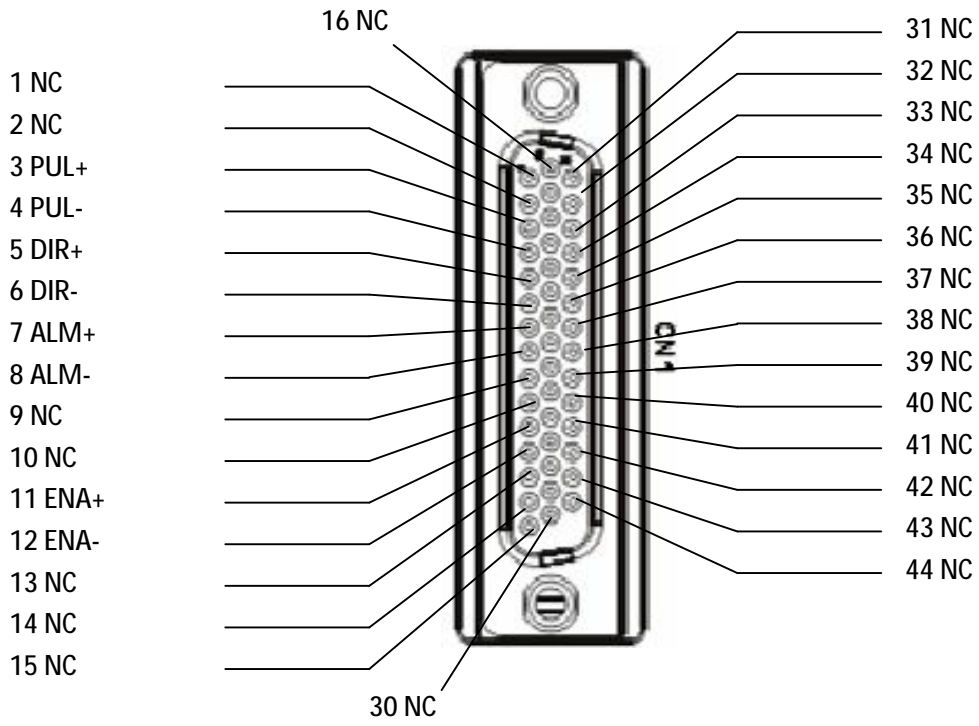

CN2 – Feedback Signal Connector

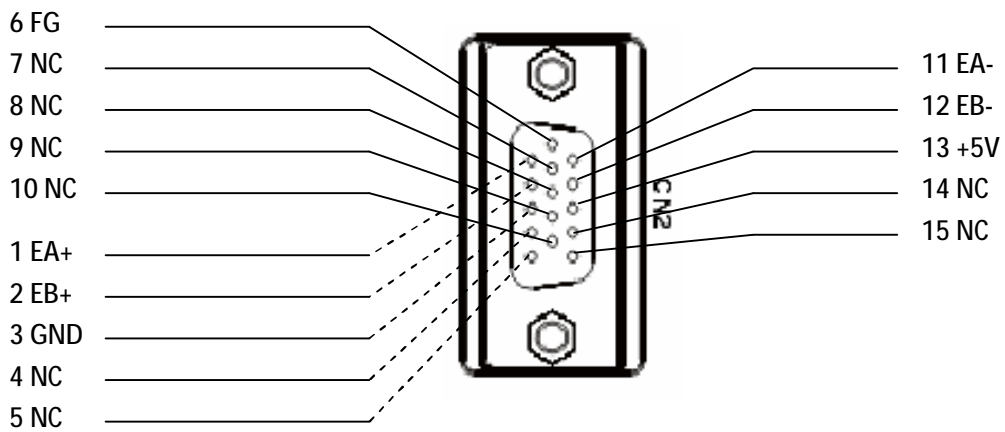

Connector Pin-Out (Continued)

CN4 – RS232 & RS485 Connector

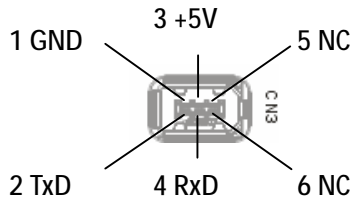

CN5 – Main Power Supply Connector

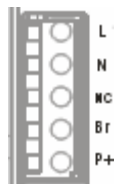

CN6 – Motor & Control Power Supply Connector



ES-MH Series Easy Servo Motors

	ES-MH33480	ES-MH342120	ES-MH342200
Step Angle (°)	1.2	1.2	1.2
Holding Torque (N.m)	8.0	12.0	20.0
Phase Current (A)	3.5	4.2	4.5
Phase Resistance (Ohm)	-	1.2	-
Phase Inductance (mH)	-	13	-
Shaft Inertia (g.cm ²)	-	-	-
Weight (Kg)	5.6	8.6	10.5
Encoder (lines / Rev.)	1000	1000	1000

Wiring Diagram

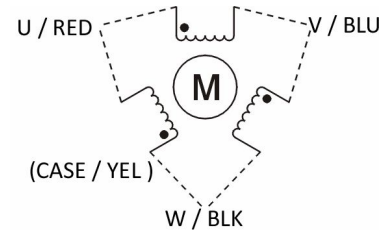

Motor Encoder Cable Pin-Out

ES-MH33480, ES-MH342120, ES-MH342200

Pin	Name	Wire Color	I/O	Description
1	EA+	Black	O	Channel A+ output
2	VCC	Red	I	+5V power input
3	GND	White	GND	Ground
11	EB+	Yellow	O	Channel B+ output
12	EB-	Green	O	Channel B- output
13	EA-	Blue	O	Channel A- output

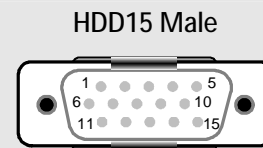

Motor Encoder Extension Cable

CABLEG-BMXXMX

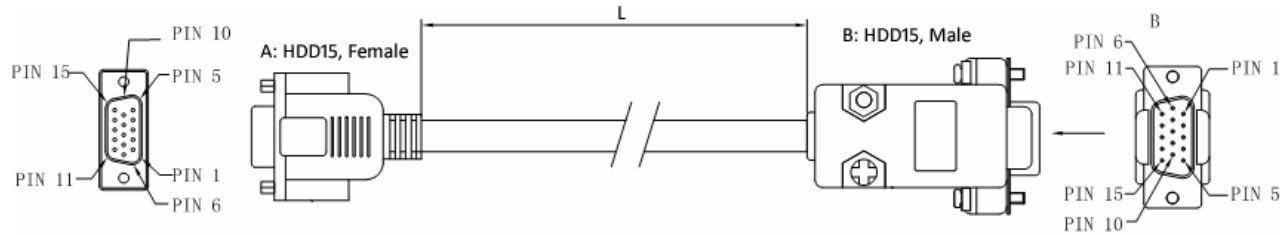

Pin Assignments

A: HDD15 Female	Wire Color	B: HDD15 Male	Name	Description
Pin		Pin		
1	Black	1	EA+	Channel A+
2	Red	13	VCC	+5V power input
3	White	3	GND	+5V GND
11	Yellow	2	EB+	Channel B+
12	Green	12	EB-	Channel B-
13	Blue	11	EA-	Channel A-

Cable Length

Part Number	L	Matching Motor
CABLEG-BM3M0	3.0m	ES-MH33480, ES-MH342120, ES-MH342200
CABLEG-BM8M0	8.0m	
CABLEG-BM10M0	10.0m	
CABLEG-BM12M0	12.0m	

Note: The encoder extension cable must be connected between the ES-MH3 motor and the ES-DH2306. You can not connect the motor's encoder cable to the ES-DH2306 directly.

Motor Power Extension Cable

CABLEH-RZXXMX

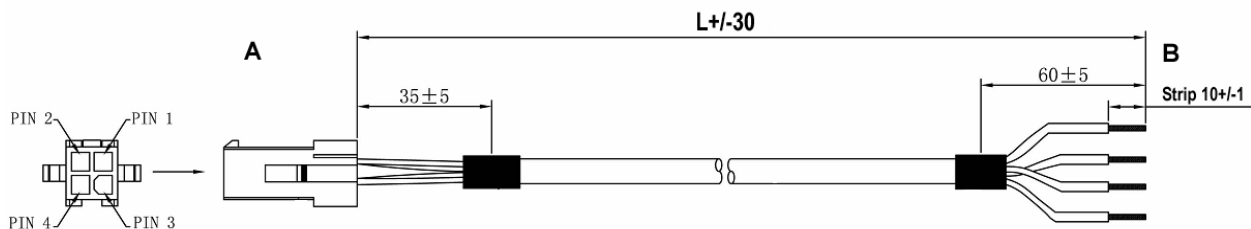

Motor Power Extension Cable (Continued)

CABLEH-RZXXM

Pin Assignments

A	B	Name	Description
Pin	Wire Color		
1	Blue	V	Motor Phase V
2	Red	U	Motor Phase U
3	Black	W	Motor Phase W
4	Yellow / Green	PE	Motor Case

Cable Length

Part Number	L	Matching Motor
CABLEH-RZ3M0	3.0m	ES-MH33480, ES-MH342120, ES-MH342200
CABLEH-RZ5M0	5.0m	
CABLEH-RZ10M0	10.0m	

Typical Connections

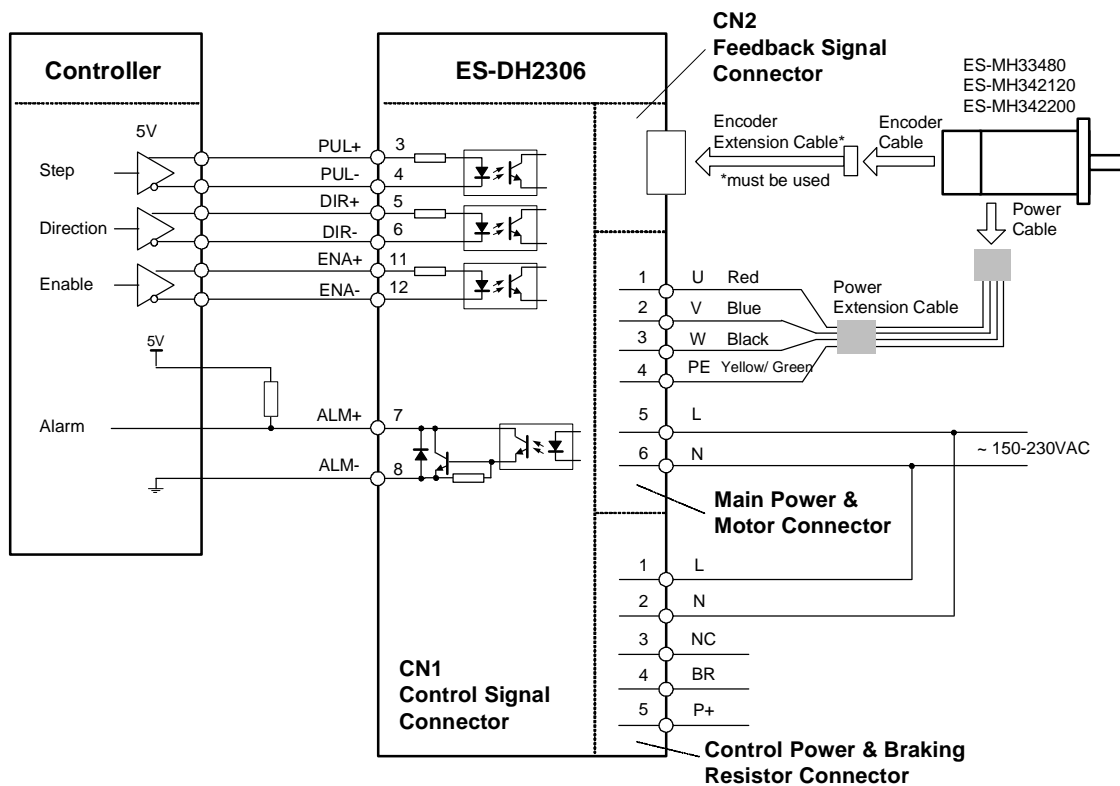

Connections to controller of differential output

Typical Connections (Continued)

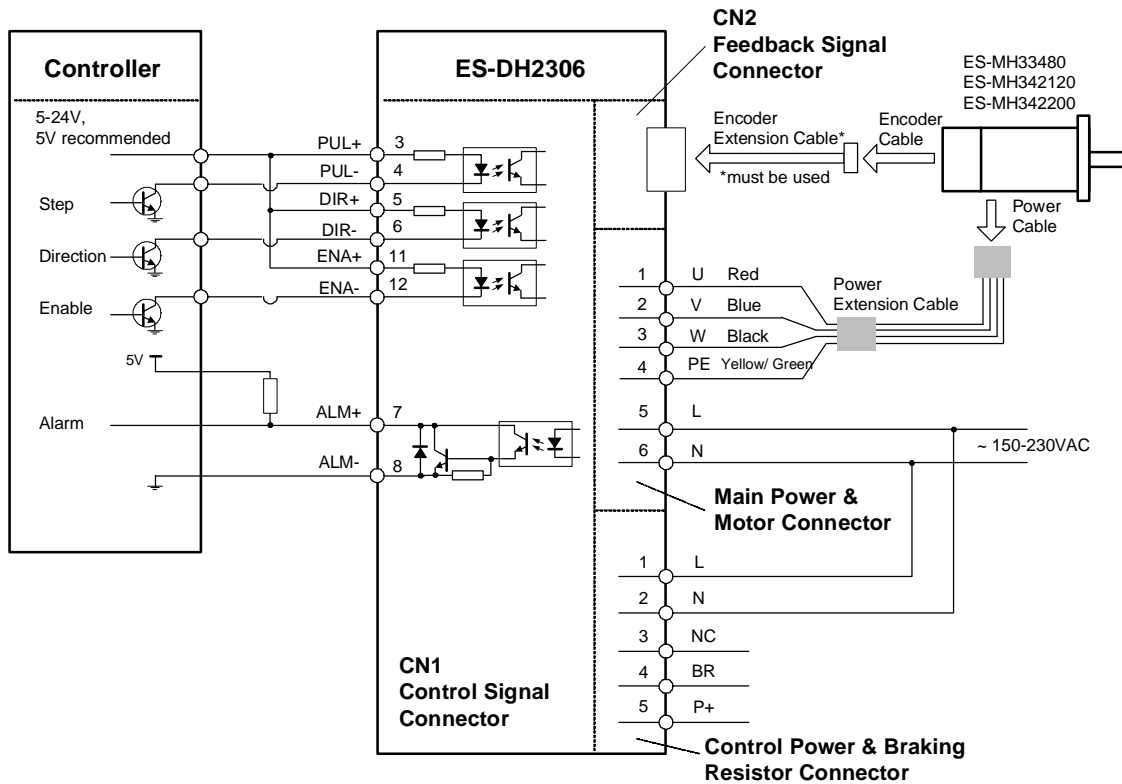

Connection to controller of sinking output

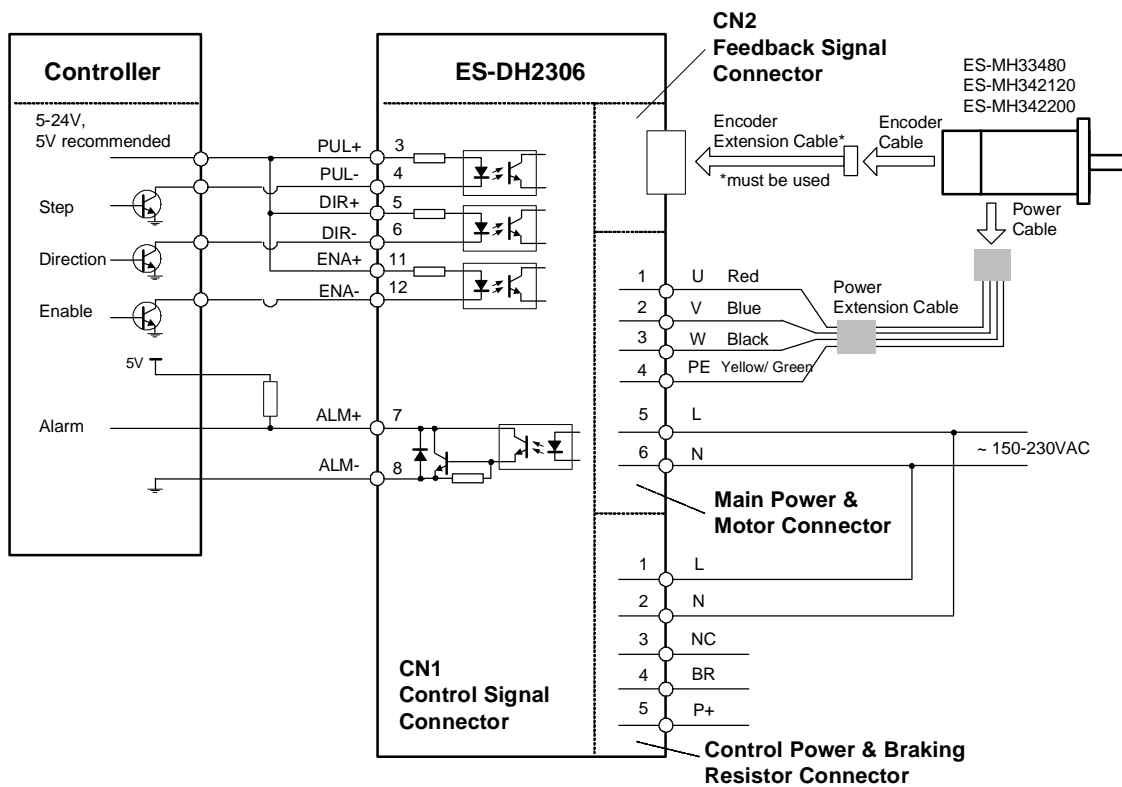

Connection to controller of sourcing output