

Rated Voltage (Vac)	200-220
Rated Power (w)	400
Rated Torque (N.m)	1.27
Peak Torque (N.m)	4.46
Rated Speed (rpm)	3000
Peak Speed (rpm)	6500
Rated Current (Amp)	3.2
Peak Current (Amp)	11.2
Torque Const (N.m/Amp)	0.4
Back EMF Const (V/krpm)	23.5
Resistance (Ω)	2.64
Inductance (mH)	7.9
Inertia (kg*m ² *10 ⁻⁴)	0.56
Poles	10
Encoder type	23bit absolute
Protection level	IP65

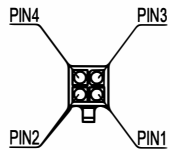
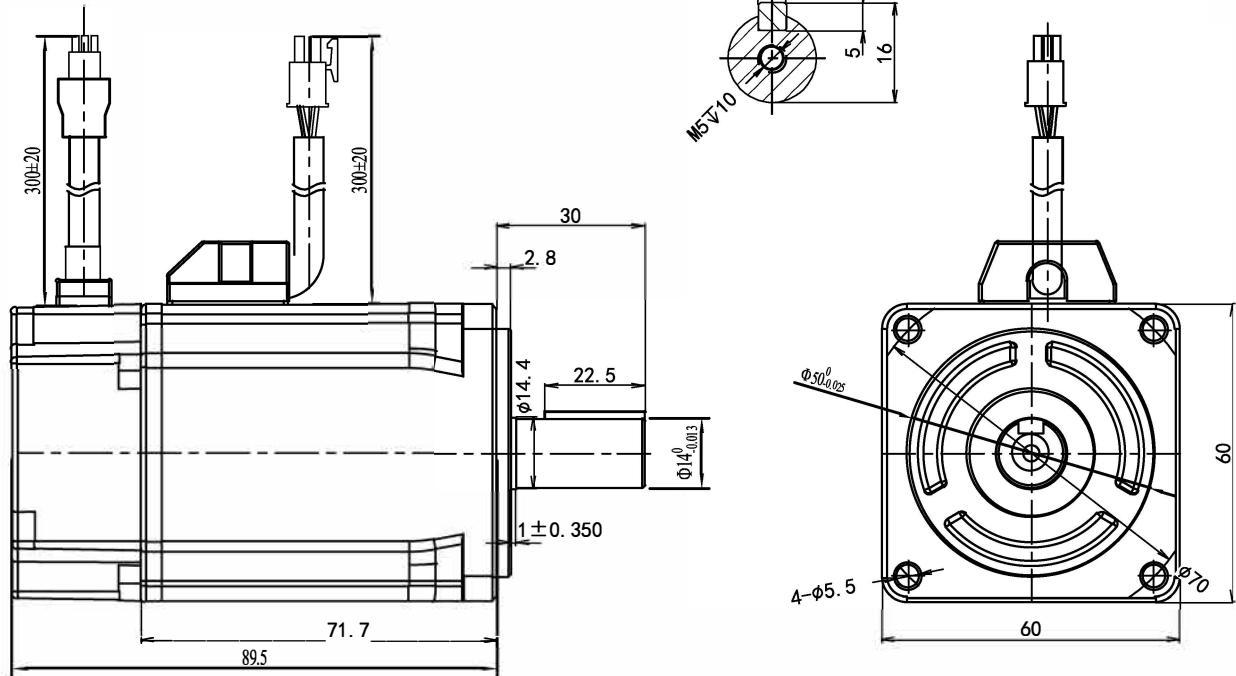

Wiring details of Power cable connector				
Pos	1	2	3	4
Signal	U	W	V	PE
Color	blue	red	black	Yel/Gre

Connector Code Of Extension Cable Side			
Type	Winding Connector	Encoder Connector	Brake Connector
Pin	170362-1	170361-1	--
Plastic shell	AMP172159-1	AMP172161-1	--

Connector Code Of Motor Side			
Type	Winding Connector	Encoder Connector	Brake Connector
Pin	170360-1	170359-1	--
Plastic shell	AMP172167-1	AMP172169-1	--

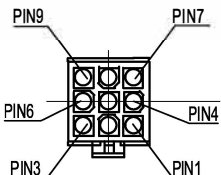

Wiring details of encoder cable connector							
Pos	1	2	3	4	5	6	7
Signal	PE	5V	0V	SD+	SD-	BAT+	BAT-
Color	shield	red	black	blue	yellow	brown	white

ELM0400LH60F-SS
 60mm, high inertia, 400w servo motor
 23bit absolute encoder, no brake