

TA Series of Temperature Controller Instruction Manual

Thanks a lot for selecting Sanyou products!

Before operating this instrument, please carefully read this manual and fully understand its contents. If have problems, please contact our sales or distributors whom you buy from. This manual is subject to change without prior notice.

Warning

Please do not turn on the power supply until all of the wiring is completed. Otherwise electrical shock, fire or malfunction may result. Do not wire when the power is on. Do not connect the unused terminals. Do not turn on the power supply when cleaning this instrument. Do not disassemble, repair or modify the instrument. This may cause electrica shock, fire or malfunction. Use this instrument in the scope of its specifications. Otherwise fire or malfunction may result. The use life of the output relay is quite different according to its capacity and conditions. If use out of its scope, fire or malfunction may result.

Caution

This instrument should be installed in a domestic environment. Otherwires electrica shock, fire or malfunction may result. The operating temperature environment should between 0°C (32F) to 50°C (122F). To avoid using this instrument in environment full of dust or caustic gas. To avoid using this instrument in environment of strong shock or concussion. To avoid using this instrument in environment of overflow water or explosive oil.

The power supply wire should not put together with large current wire to avoid electromagnetic radiation, If it must to put together, we suggest to use a individual pipe. In case the instrument is used in environment of strong noise, (such as motor, transformer, solenoid, etc.) A current suppresser or noise filter should be used.

Applications

TA series of temperature controller is available for many TC or RTD input, adopt some advanced techonology such multi digital filter circuit, autotune PID, fuzzy PID that make it is very precise, stable, strong anti-interference and simple operation. The instrument is widely applied to

automation systems of mechanism, chemical industrial, chinaware, light industrial, metallurgy and petroleum chemical industrial. It is also applied to the production line of foodstull, packing, printing, dry machine, metal heat process equipment to control the temperature.

Name of parts

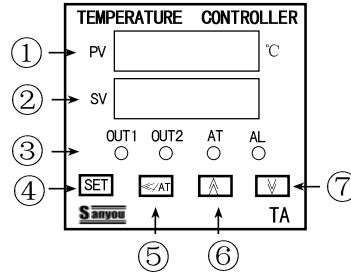

- 1.Measured value (PV)/Various parameter symbols
- 2.Set value (SV)/Various parameters set value
- 3.Indication lamps

OUT1: Heating/Main control output lamp On: Ouput

Off: No output

OUT2: Cooling/Alam2 output lamp On: Ouput Off: No output

AT: Autotune lamp On: Autotune Off: Non-autotune

AL: Alarm 1 output lamp On: Alarm Off: No Alarm

4.Set key Parameter Setting/Changing

5.Shift/Autotune key Press this key to shift digit of parameter value setting. Or hold this key for more than 3 seconds can enter/quit autotune estate. When enter autotune estate, AT lamp on. When quit autotune estate,

AT lamp off.

6.Up key Used to increase numerals

7.Down key Used to decrease numerals

Models

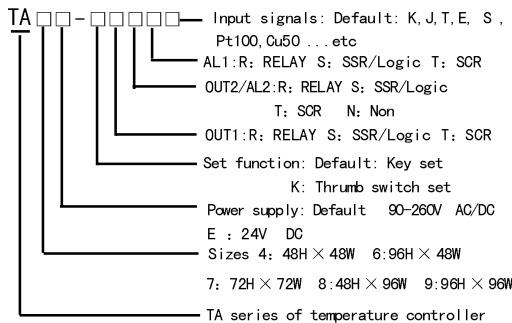

Specifications

Power supply	90-260V AC/DC 50/60Hz	
Consumption	≤ 5VA	
Display range	-199~1800°C	
Accuracy	0.3%F.S ± 2digit	
Sampling cycle	≤ 300ms	
Main output	RELAY: normal open AC 250V/3A DC 30V/3A COSφ=1 SSR/LOGIC : TA4/TA6 : 24V DC ± 2V/ 20mA TA7/ TA9 : 12V ± 1V/ 20mA	
Alarm	RELAY: normal open AC 250V/3A DC 30V/3A COSφ=1 SSR/LOGIC: TA4/TA6 : 24V DC ± 2V/ 30mA TA7/TA9: 12V ± 1V/ 20mA	
Input	T/C	
	K	0~999°C/0~1200°C
	J	0~999°C /0~1200°C
	T	-150~400°C (Special order)
	S	0~1600°C
	E	0~1000°C
Rt	Pt100	-199~600°C
	Cu50	-50~150°C
	Others	Please mention when ordering
Withstand voltage strength	1500V Rms (Between power terminal and the housing)	
Insulation resistance	Min 50MΩ (500V DC) (Between power terminal and the housing)	
Environment temperature	0~50°C	
Save temperature	-10~60°C	
Environment humidity	35~85%RH	
Weight	TA4: ≤ 250g TA6, TA7, TA8, TA9 ≤ 350g	

Mounting and Sizes

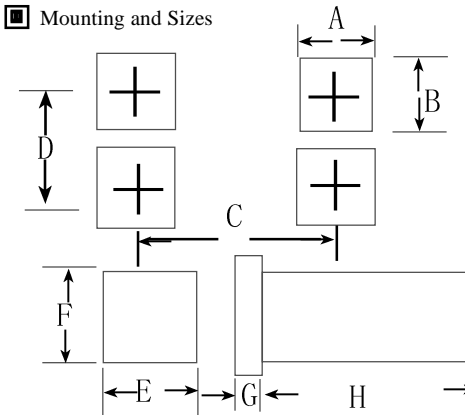

Sizes Model	A	B	C	D	E	F	G	H
TA4	44.5+0.5	45+0.5	65	65	48	48	8	80
TA6	43.5+0.5	91+0.5	65	115	48	96	12	100
TA7	67.5+0.5	67.5+0.5	95	95	72	72	12	100
TAB	91+0.5	43.5+0.5	65	115	96	48	12	100
TA9	91+0.5	91+0.5	115	115	96	96	12	100

Parameter setting

Setting steps

- Select the parameter you want to modify
- Press the <</AT or <</M key to select the digit you want to modify
- Press ^ key and v key to modify the numerals
- Press SET key to confirm

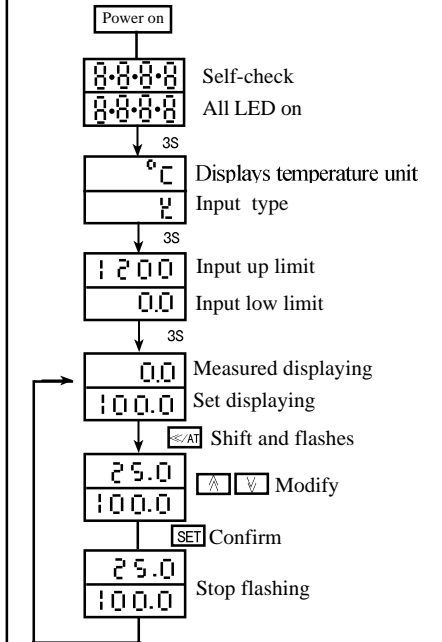

In Non-autotune estate, press and hold ^ / v key for more than 5 seconds can enter/quit the under menu: (Normally the program will refresh the value of the parameters by itself, the user no need make modifications.)

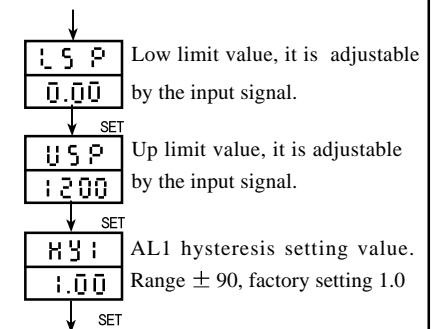

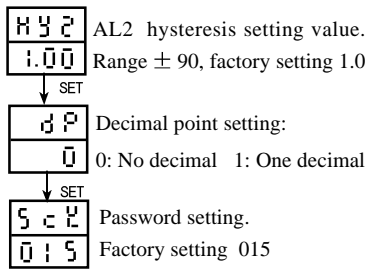

The values on down line are the factory setting values

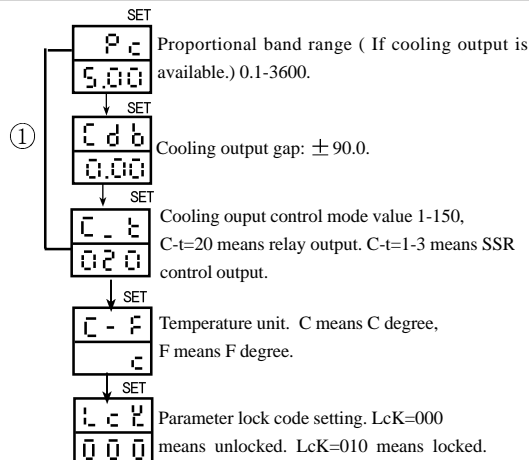
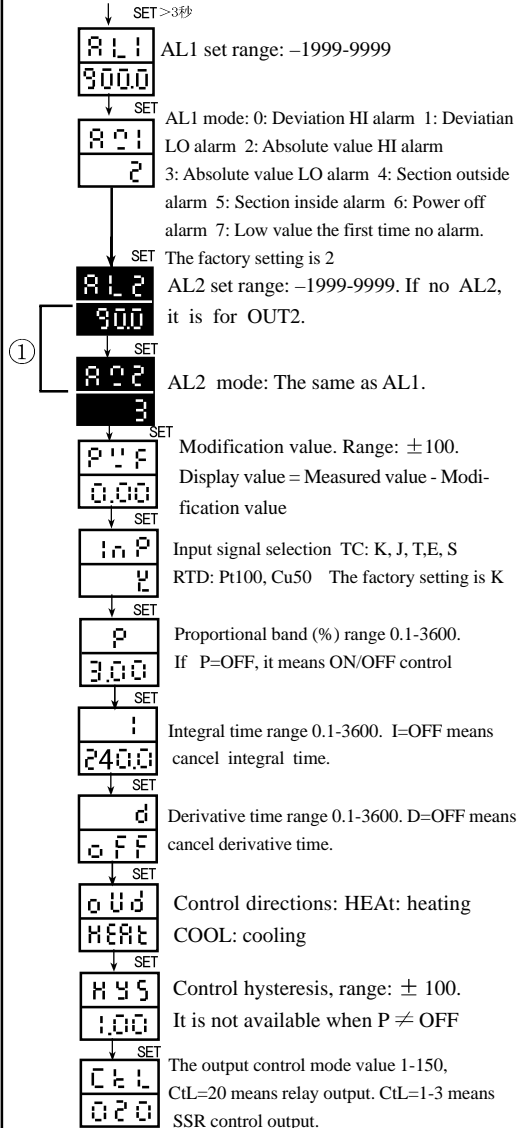

Note:

1.OUT2 and AL2 use the the same output channel. It is for the user's option. Set by the factory.

When the user operate the instrument at first time, please operate according to the processes of this instruction manual. Let the instrument in autotuning, if the runing conditions keep not change (eg. Running the same equipment), the user no need to let it autotuning again. Because the instrument has recorded the previous PID parameters. When the instrument is used for huge capacity heating equipments, the user should set autotuning value lower 5%-10% than the normal control value, in order to decrease the exceed-tuning caused by control.

In normally, the control cycle of the heating equipment should be 20-30 seconds. For huge capacity heating equipments, the value should be 30-120 seconds, in order to longer the use life of the relay. For non-contact output, such as SSR control output, the value should be 1-3.

Terminal configurations

(If any changed, please refer to the product showing.)

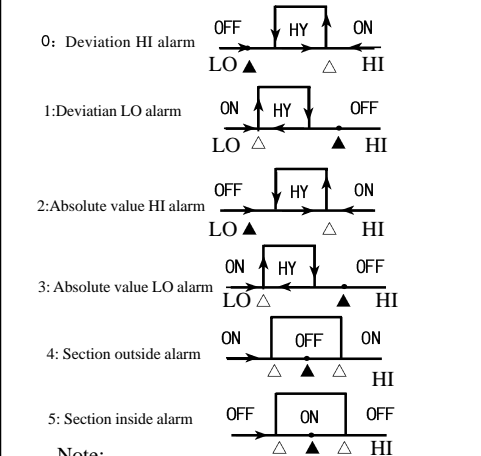
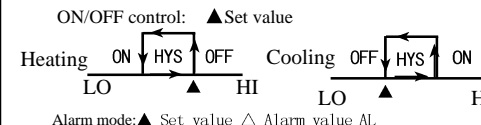
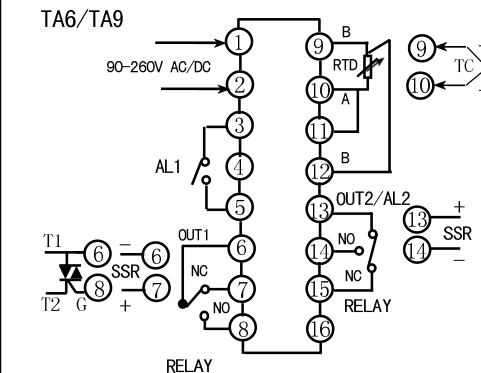
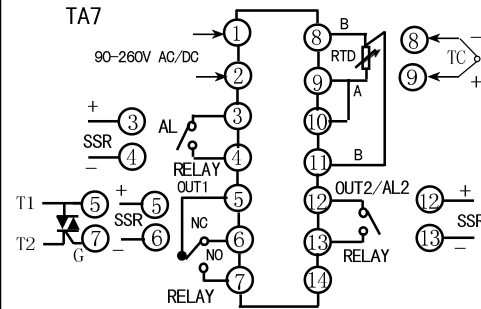
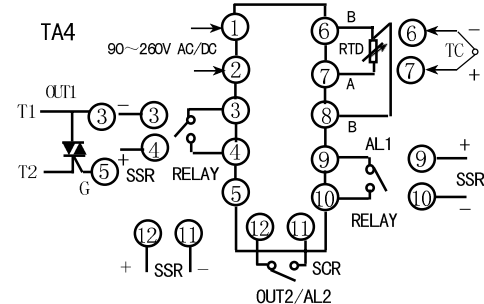

Note:
All the factory setting value of deviation alarm is 1.0. If the user want to change, please contact us or our distributors.

Application examples

1. Relay output control (for TA9)

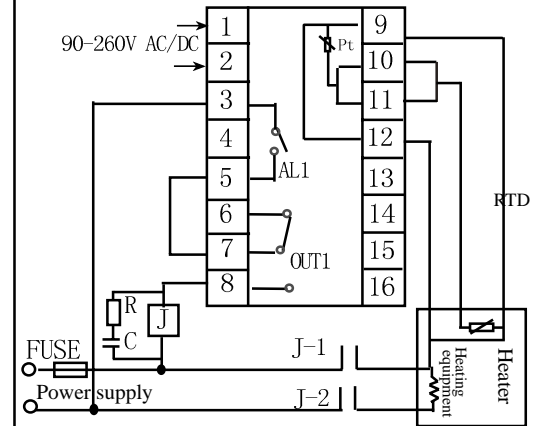

Malfunction estimate

① No Display : Check all the connection and wiring if it is all correct. Specially pay attention to the power supply terminals and signal input terminals.

② Incorrect Display: Check if the input signal is conformity with the selected symbol.

For TC input, please use the relative compensation cable. For RTD input, please use low impedance cable. The 3 wires should at the same length.

If all above mentioned is collect, please use parameter PVF to modify.

③ Incorrect Control : If the instrument has been used for a long time, the user find that the displaying float or the temperature is hard to rise up to the set value, meanwhile the outsidessystem running well, there must be something wrong with the parameters of the instrument.

The user need to re-autotuning the instrument. If the instrument lost control, please check if the connection of the control is correct. If external load is shorted, broken, wrong connection or components is damaged, it will cause lost control as well. When it is necessary, please push out the PCB to check the if the output terminals is damaged and not available.

④ Display malfunction : "UUUU": The input signal exceed the measured HI range. "LLLL": The input signal exceed the measured LO range, or input signal terminal connection is contrary.