

User's Manual

For

8078

High Performance Microstepping Driver

Version 1.0

©2000 All Rights Reserved

Attention: Please read this manual carefully before using driver!

Table of Contents

1. Introduction, Features and Applications	2
2. Specifications and Operating Environment	3
3. Driver Connectors P1 and P2	4
4. Control Signal Connector (P1) Interface	4
5. Driver Connection to Motors (P2)	5
6. Power Supply and Driver Voltage and Current	9
7. Selecting Microstep Resolution and Driver Current	11
8. Changing Microstep Resolution on-the-fly	12
9. Connection Diagram for Driver, Motor, Controller	13
10. Control Signal Waveform and Timing	14

1. Introduction, Features and Applications

8078 are high performance microstepping drivers based on most advanced technology in the world today. They are suitable for driving any 2-phase and 4-phase hybrid step motors. By using advanced bipolar constant-current chopping technique, they can output more speed and power from the same motor, compared with traditional technologies such as L/R drivers. Its 3-state current control technology allows coil currents to be well controlled, with relatively small current ripple and results in less motor heating.

Features of this driver

- High performance, low cost
- Supply voltage up to +80VDC, current to 7.8A
- Inaudible 20khz chopping frequency
- TTL compatible and optically isolated input signals
- Automatic idle-current reduction
- Mixed-decay current control for less motor heating
- 14 selectable resolutions in decimal and binary
- Microstep resolutions up to 51,200 steps/rev
- Suitable for 4,6,8 lead motors
- Over-current, over-voltage and short-circuit protection
- Small size (119 x 97 x 48mm)

Applications of this driver

Suitable for a wide range of stepping motors of size Nema 34 and 43, and usable for various kinds of machines, such as X-Y tables, labeling machines, laser cutters, engraving machines, and pick-place devices, particularly useful in applications with low vibration, high speed and high precision requirements.

2. Specifications and Operating Environment

Electric Specifications ($T_i = 25^\circ\text{C}$)

Parameters	8078			Remark
	Min.	Typical	Max.	
Peak Output Current	2.8A,	by user	7.8A,	By DIP switch
Supply voltage (DC)	+18V	+68V	+80V	
Logic signal current	10mA	12mA	18mA	
Pulse input frequency	0	By user	300Khz	
Isolation resistance	500M Ω			

Operating Environment and Parameters

Cooling	Natural cooling or forced convection	
Environment	Space	Avoid dust, oil frost and corrosive gas
	Temperature	0 $^\circ$ - 50
	Humidity	40 - 90%RH
	Vibration	5.9m/s ² Max
Storage Temp.	-20 - +65	
Weight	About 0.44kg	

Mechanical Dimensions

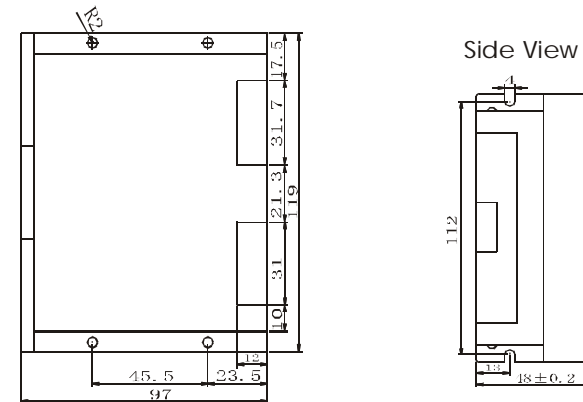

Figure 1: Mechanical dimensions

3. Driver Connectors, P1 and P2

The driver has two connectors, P1 for control signals, and P2 for power and motor connections.

The following is a brief description of the two connectors of the driver. More detailed descriptions of the pins and related issues are presented in section 4, 5, 6, 9.

Control Signal Connector P1-pins

Pin No.	Signal	Functions
1	Pul + (+5V)	Pulse signal: in single pulse(pulse/direction) mode, this input represents pulse signal, effective for each upward – rising edge; in double pulse mode (pulse/pulse) this input represents clockwise(CW)pulse. For reliable response, pulse width should be longer than 3 μ s.
2	Pul - (pulse)	
3	Dir + (+5V)	Direction signal: in single-pulse mode, this signal has low/high voltage levels, representing two directions of motor rotation; in double-pulse mode (set by inside jumper JMPI), this signal is counter-clock (CCW) pulse, effective on each rising edge. For reliable motion response, direction signal should be sent to driver 2 μ s before the first pulse of a motion direction reversal.
4	Dir - (Dir)	
5	Ena+(+5V)	Enable signal: this signal is used for enable/disable, high level for enabling driver and low level for disabling driver. Usually left unconnected(enabled).
6	Ena- (Ena)	

Remark 1: Pul/dir is the default mode, under-cover jumper JMP1 can be used to switch to CW/CCW double-pulse mode.

Remark 2: Please note motion direction is also related to motor-driver wiring match. Exchanging the connection of two wires for a coil to the driver will reverse motion direction. (for example, reconnecting motor A+ to driver A- and motor A- to driver A+ will invert motion direction).

Power connector P2 pins

Pin No.	Signal	Functions
1	Gnd	DC power ground
2	+V	DC power supply, +18VDC - +80VDC, Including voltage fluctuation and EMF voltage.
3, 4	Phase A	Motor coil A (leads A+ and A-)
5, 6	Phase B	Motor coil B (leads B+ and B-)

4. Control Signal Connector (P1) Interface

This driver uses differential inputs to increase noise immunity and interface flexibility. Single-ended control signals from the indexer/controller can also be accepted by this interface. The input circuit has built-in high-speed opto-coupler, and can accept signals in the format of line driver, open-collector, or PNP output. Line driver (differential) signals are suggested for reliability. In the following figures, connections to open-collector and PNP signals are illustrated.

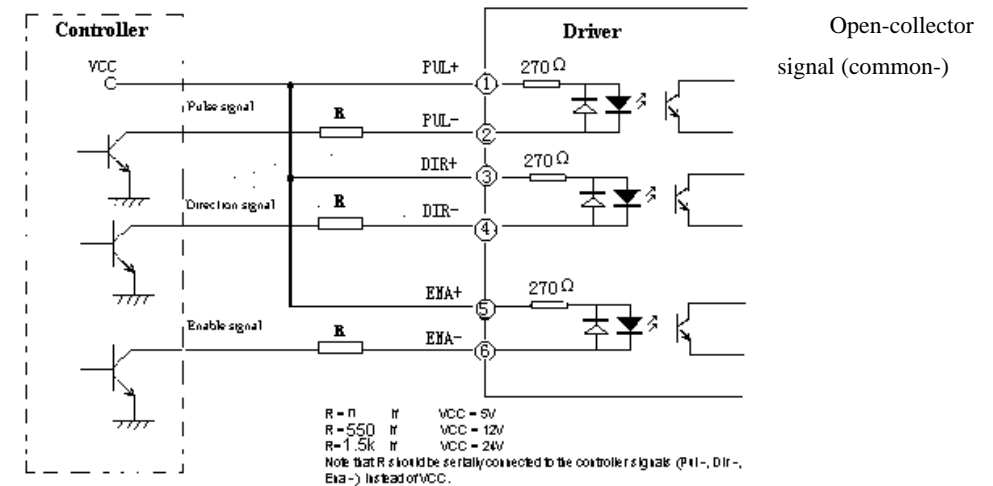

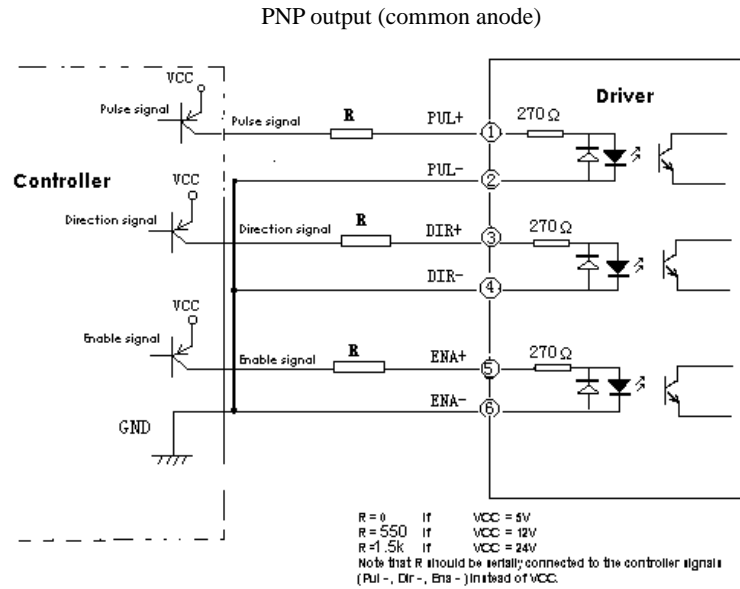
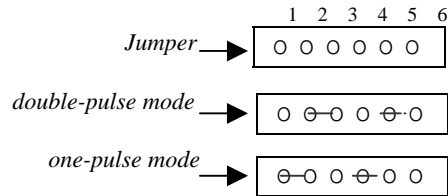

Figure 2: Signal Interface

Single Pulse and Double Pulse Modes

There is a jumper JMPI inside the driver specifically for the purpose of selecting pulse signal mode. settings for one-pulse mode (pulse/dir) and for double-pulse mode (CW/CCW) are shown on the left. Default mode out of factory is one pulse Mode.



5. Driver Connection to Step Motors

8078 driver can drive any 4, 6, 8 lead hybrid step motors. The following diagrams illustrate connection to various kinds of motor leads:

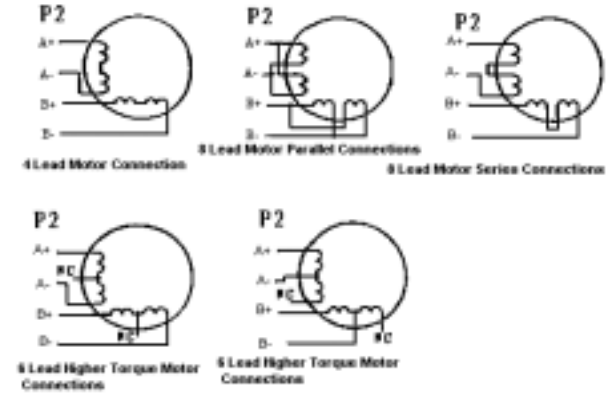

Note that when two coils are parallelly connected, coil inductance is reduced by half and motor speed can be significantly increased. Serial connection will lead to increased inductance and thus the motor can be run well only at lower speeds.

5.1 Connecting to 8-Lead Motors

8 lead motors offer a high degree of flexibility to the system designer in that they may be connected in series or parallel, thus satisfying a wide range of applications.

Series Connection

A series motor configuration would typically be used in applications where a higher torque at lower speeds is required. Because this configuration has the most inductance, the performance will start to degrade at higher speeds. Use the per phase (or unipolar) current rating as the peak output current, or multiply the bipolar current rating by 1.4 to determine the peak output current.

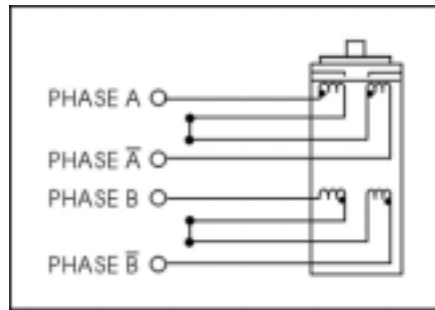

Figure 4: 8 Lead Motor Series Connections

Parallel Connection

An 8 lead motor in a parallel configuration offers a more stable, but lower torque at lower speeds. But because of the lower inductance, there will be higher torque at higher speeds. Multiply the per phase (or unipolar) current rating by 1.96, or the bipolar current rating by 1.4, to determine the peak output current.

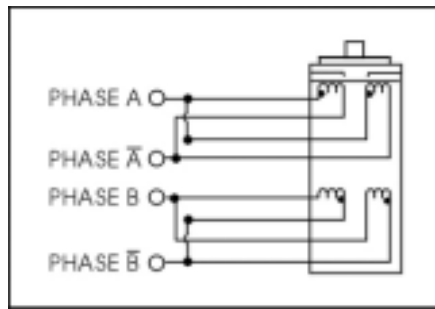

Figure 5: 8 Lead Motor Parallel Connections

5.2 Connection to 6-Lead Motors

Like 8 lead stepping motors, 6 lead motors have two configurations available for high speed or high torque operation. The higher speed configuration, or half coil, is so described because it uses one half of the motor's inductor windings. The higher torque configuration, or full coil, use the full windings of the phases.

Half Coil Configuration

As previously stated, the half coil configuration uses 50% of the motor phase windings. This gives lower inductance, hence, lower torque output. Like the parallel connection of 8 lead motor, the torque output will be more stable at higher speeds. This configuration is also referred to as bal copper. In setting the driver output current multiply the specified per phase (or unipolar) current rating by 1.4 to determine the peak output current.

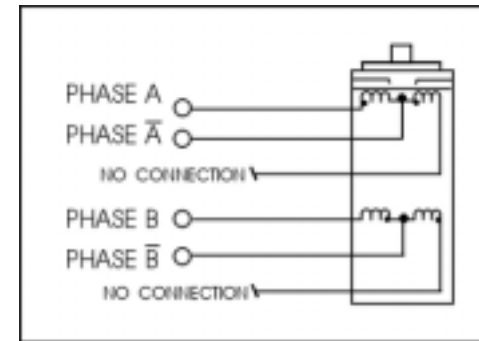

Figure 6: 6 Lead Half Coil (Higher Speed) Motor Connections

Full Coil Configuration

The full coil configuration on a six lead motor should be used in applications where higher torque at lower speeds is desired. This configuration is also referred to as full copper. Use the per phase (or unipolar) current rating as the peak output current.

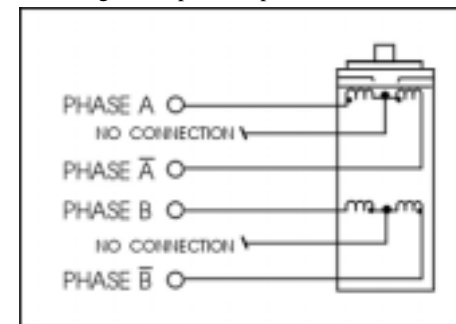

Figure 7: 6 Lead Full Coil (Higher Torque) Motor

5.3 Connection to 4-Lead Motors

4 lead motors are the least flexible but easiest to wire. Speed and torque will depend on winding inductance. In setting the driver output current, multiply the specified phase current by 1.4 to determine the peak output current.

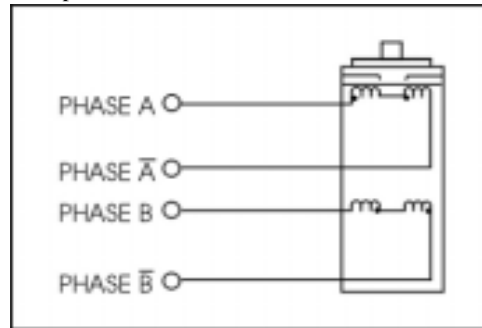

Figure 8: 4 Lead Motor Connections

6. Power supply Selection, Driver Voltage and Current Selection

6.1 Power Supply Selection

It is important to choose appropriate power supply to make the driver operate properly and deliver optimal performance.

Maximum Voltage Input:

The power MOSFETS inside the driver can actually operate within +18V - +80VDC, including power input fluctuation and back EMF voltage generated by motor coils during motor shaft deceleration. Higher voltage will damage the driver. Therefore, it is suggested to use power supplies with theoretical output voltage of no more than +95V, leaving room for power line fluctuation and Back EMF.

Regulated or Unregulated power supply:

Both regulated and unregulated power supplies can be used to supply DC power to the driver. However, unregulated power supplies are preferred due to their ability to withstand current surge. If regulated power supply (such as most switching supplies.) is indeed used, it is important to have large current output rating to avoid problems like current clamp, for example using 4A supply for 3A motor-driver operation. On the other hand, if unregulated supply is

used, one may use a power supply of lower current rating than that of motor (typically 50% ~ 70% of motor current). The reason is that the driver draws current from the power supply capacitor of the unregulated supply only during the ON duration of the PWM cycle, but not during OFF duration. Therefore, the average current withdrawn from power supply is considerably less than motor current. For example, two 3A motors can be well supplied by one power supply of 4A rating.

Multiple drivers:

It is recommended to have multiple drivers to share one power supply to reduce cost, provided that the supply has enough capacity. To avoid cross interference, **DO NOT** daisy-chain the power supply input pin of the drivers (connect them to power supply separately). Higher supply voltage will allow higher motor speed to be achieved, at the price of more noise and heating. If the motion speed requirement is low, it's better to use lower supply voltage to improve noise, heating and reliability. NEVER connect power and ground in the wrong direction, as it will damage the driver.

6.2 Driver Voltage and Current Selection

This driver can match small and medium size step motors (NEMA 34 and 43) made by Leadshine or other motor manufactures from around the world. To achieve good driving results, it is important to select supply voltage and output current properly. Generally, supply voltage determines the high speed performance of the motor, while output current determines the output torque of the driven motor (particularly at lower speed).

Selecting Supply Voltage:

Higher supply voltage can increase motor torque at higher speeds, thus helpful for avoiding losing steps. However, higher voltage may cause more motor vibration at lower speed, and it may also cause over-voltage protection and even driver damage. Therefore, it is suggested to choose only sufficiently high supply voltage for intended applications.

Setting Proper Output Current

- For a given motor, higher driver current will make the motor to output more torque, but at the same time causes more heating in the motor and driver. Therefore, output current is generally set to be such that the motor will not overheat for long time operation.
- Since parallel and serial connections of motor coils will significantly change resulting inductance and resistance, it is therefore important to set driver output current depending on motor phase current, motor leads and connection methods.

- c. Phase current rating supplied by motor manufacturer is important to selecting driver current, but the selection also depends on leads and connection.

7. Selecting Microstep Resolution and Driver Current Output

This driver uses an 8-bit DIP switch to set microstep resolution, and motor operating current, as shown below:

Current during motion Microstep resolution

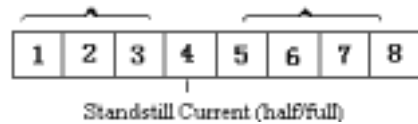

7.1 Microstep Resolution Selection

Microstep resolution is set by SW5, 6, 7, 8 of the DIP switch as shown in the following table:

Microstep	ustep/rev.(for 1.8 ° motor)	SW5	SW6	SW7	SW8
2	400	on	on	on	on
4	800	on	off	on	on
8	1600	on	on	off	on
16	3200	on	off	off	on
32	6400	on	on	on	off
64	12800	on	off	on	off
128	25600	on	on	off	off
256	51200	on	off	off	off
5	1000	off	on	on	on
10	2000	off	off	on	on
25	5000	off	on	off	on
50	10000	off	off	off	on
125	25000	off	on	on	off
250	50000	off	off	on	off

7.2 Current Setting

The first three bits (SW1, 2, 3) of the DIP switch are used to set the current during motion (dynamic current). Select a setting closest to your motor's required current.

● DIP Setting for current during motion:

8078	SW1	SW2	SW3
2.8A	on	on	on
3.5A	off	on	on
4.2A	on	off	on
4.9A	off	off	on
5.7A	on	on	off
6.4A	off	on	off
7.0A	on	off	off
7.8A	off	off	off

Remarks:

1) Due to motor inductance the actual current in the coil may be smaller than the dynamic current settings, particularly at higher speeds.

2) Static current setting

The current automatically reduced to 60% of dynamic current setting 1 second after the last pulse. This will, theoretically, reduce motor heating to 36% (due to I^2R) of the original value. If the application needs a different idle current, please contact Leadshine for minor modification of circuit.

● DIP setting for current during standstill:

SW4 is used for this purpose, current setting due to coil inductance. OFF meaning that the standstill current is set to be half of the dynamic current, and ON meaning that standstill current is set to be the same as dynamic current.

8. Protection Functions

To improve reliability, the driver incorporates a number of built-in protection features.

a. Over-voltage protection

When power supply voltage exceeds +80VDC, protection will be activated and power indicator LED will turn red. When power supply voltage is lower than +18VDC, the driver will not work properly.

b. Coil-ground Short Circuit Protection

Protection will be activated in case of short circuit between motor coil and ground.

c. Over-current Protection

Protection will be activated in case of short current which may otherwise damage the driver.

Attention: since there is no protection against power leads (+, -) reversal, it is critical to make sure that power supply leads are correctly connected to driver. Otherwise, the driver will be damaged instantly.

9. Connection Diagram for Driver, Motor, Controller

A complete stepping system should include stepping motor, stepping driver, power supply and controller (pulse generator).

A typical connection is shown below:

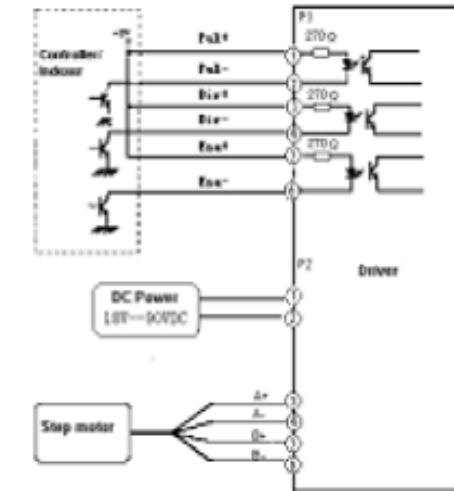

Figure 9: Driver connection in a stepping system

10. Control signal Waveform and Timing

This driver can accept pulse control signals up to 500kHz. Before a direction reversal, direction signal needs to be established at least 2 μ s before the first pulse of the next pulse train. Please examine time diagrams of the three control signals as follows.

