

Microstepping Driver

KL6050

Applications

Suitable for a wide range of stepping motors of Nema 17 , 23 and 34, and usable for various kinds of machines, such as X-Y tables, labeling machines, laser cutters, engraving machines, and pick-place devices. Particularly useful in applications with low vibration, high speed and high precision are desired

Electric Specifications ($T_j=25^{\circ}\text{C}$)

Parameters	KL6050			
	Min	Typical	Max	Unit
Output current	1.5	-	5.0	A
Supply voltage	20	48	60	VDC
Logic signal current	7	10	16	mA
Pulse input frequency	0	-	100	KHz
Isolation resistance	500			M Ω

Mechanical Specifications (Unit: mm, 1 inch=25.4 mm)

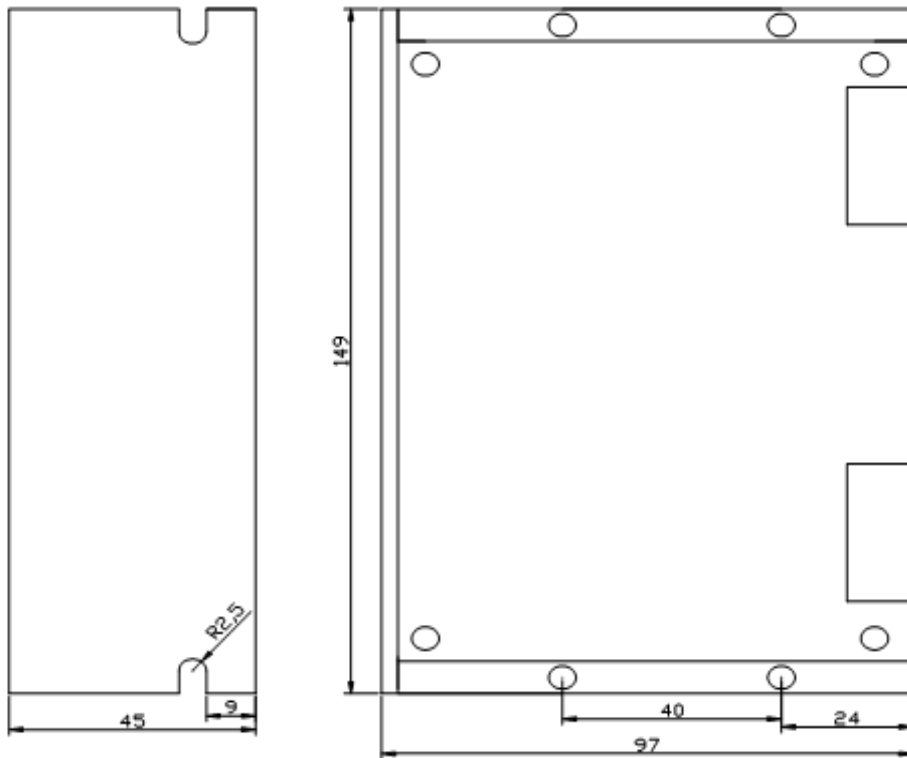

Figure 1: Mechanical Specifications

Pin Assignment and Description

Control Signal Connector P1 pins

Pin Function	Details
PUL+(+5V)	<u>Pulse signal:</u> In single pulse (pulse/direction) mode, this input represents pulse signal, effective for each rising or falling edge (set by inside R13&R14); 4-5V when PUL-HIGH, 0-0.5V when PUL-LOW. In double pulse mode (pulse/pulse), this input represents clockwise (CW) pulse, effective for high level or low level (set by inside R13&R14). For reliable response, pulse width should be longer than 1.2μs. Series connect resistors for current-limiting when +12V or +24V used.
PUL-(PUL)	
DIR+(+5V)	<u>DIR signal:</u> In single-pulse mode, this signal has low/high voltage levels, representing two directions of motor rotation; in double-pulse mode (set by inside R31&R32), this signal is counter-clock (CCW) pulse, effective for high level or low level (set by inside R13&R14). For reliable motion response, DIR signal should be ahead of PUL signal by 5μs at least. 4-5V when DIR-HIGH, 0-0.5V when DIR-LOW. Please note that motion direction is also related to motor-driver wiring match. Exchanging the connection of two wires for a coil to the driver will reverse motion direction.
DIR-(DIR)	
ENA+(+5V)	<u>Enable signal:</u> This signal is used for enabling/disabling the driver. High level (NPN control signal, PNP and Differential control signals are on the contrary, namely Low level for enabling.) for enabling the driver and low level for disabling the driver. Usually left UNCONNECTED (ENABLED) .
ENA-(ENA)	

Power connector P2 pins

Pin Function	Details
GND	DC power ground.
+V	DC power supply, 20-60VDC, Including voltage fluctuation and EMF voltage.
A+, A-	Motor Phase A
B+, B-	Motor Phase B

Microstep Resolution Selection

Microstep resolution is specified by 4 DIP switches as shown in the following table:

Microstep	SW4
1/2	1
1/8	0

Current Setting

Current	SW1	SW2	SW3
1.5	0	0	0
2.0	1	0	0
2.5	0	1	0
3.0	1	1	0
3.5	0	0	1
4.0	1	0	1
4.5	0	1	1
5.0	1	1	1

Notes: Due to motor inductance, the actual current in the coil may be smaller than the dynamic current settings, particularly under high speed condition.

Typical Connections

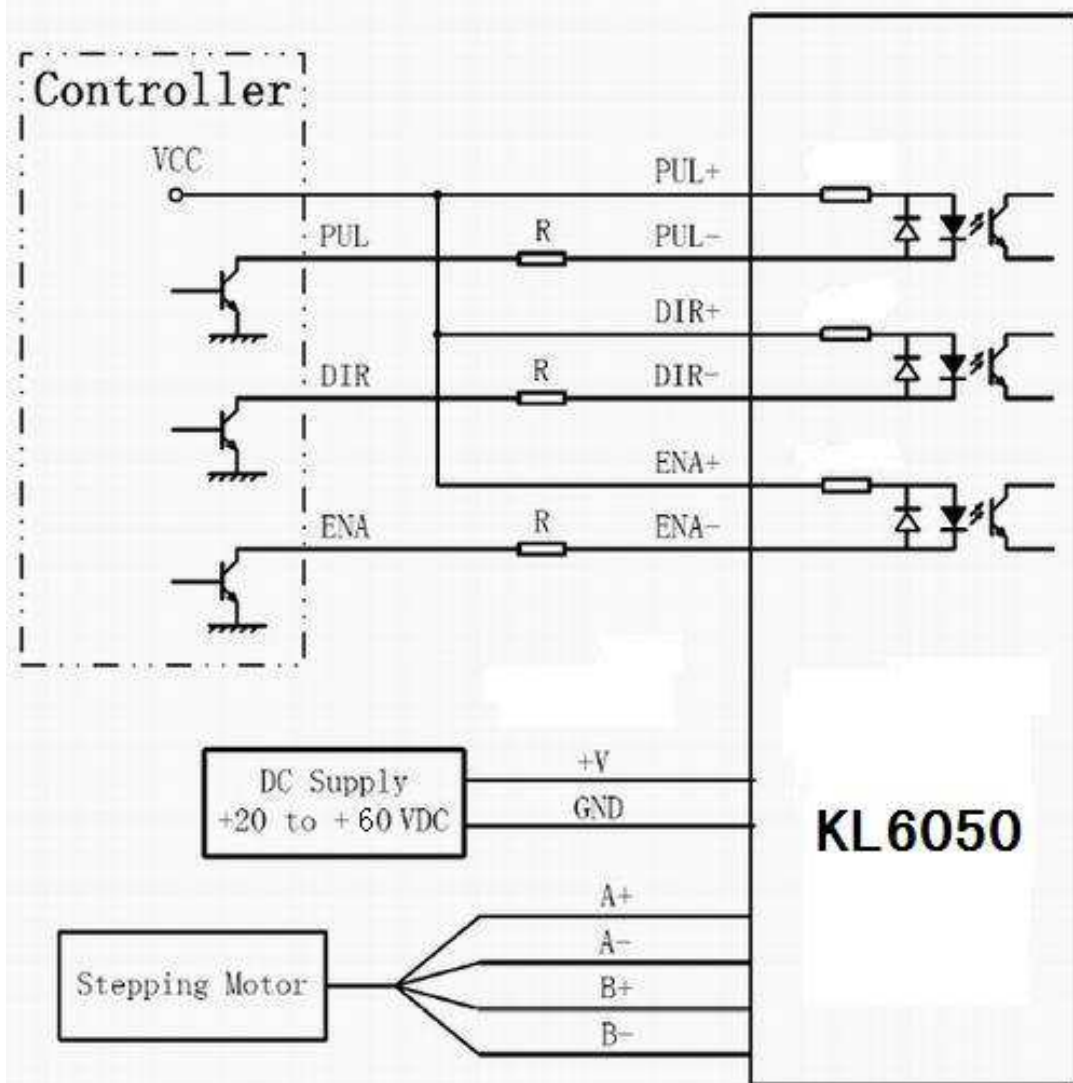

Figure 2: Typical Connections