

Microstepping Driver

KL8078

Feature

- High performance, cost-effective
- Supply voltage up to +80VDC
- Output current up to 7.8A
- Self-adjustment technology
- Pure-sinusoidal current control technology
- Pulse input frequency up to 300 KHz
- TTL compatible and optically isolated input
- Automatic idle-current reduction
- 16 selectable resolutions, up to 51,200 steps/rev
- Suitable for 2-phase and 4-phase motors
- Support PUL/DIR and CW/CCW modes
- Short-voltage, over-voltage, over-current and over temperature protection

Introduction

The KL8078 are high performance microstepping drivers based on one of the most advanced technologies in the world today. They are suitable for driving any 2-phase and 4-phase hybrid step motors. By using advanced bipolar constant-current chopping technique, they can output more speed and power from the same motor, compared with traditional technologies such as L/R drivers. Its 3-state current control technology allows coil current to be well controlled, with relatively small current ripple and results in less motor heating.

Applications

Suitable for a wide range of stepping motors of size Nema23 and 43, and usable for various kinds of machines, such as X-Y tables, labeling machines, laser cutters, engraving machines, and pick-place devices. Extremely suitable for applications expected to be low vibration, high speed and high precision.

Electric Specifications ($T_j=25^\circ\text{C}$)

Parameters	KL8078			
	Min	Typical	Max	Unit
Output current	2.8	-	7.8	A
Supply voltage	+24	+68	+80	VDC
Logic signal current	7	10	16	mA
Pulse input frequency	0	-	300	KHz
Isolation resistance	500			MΩ

Mechanical Specifications (Unit: mm, 1 inch=25.4 mm)

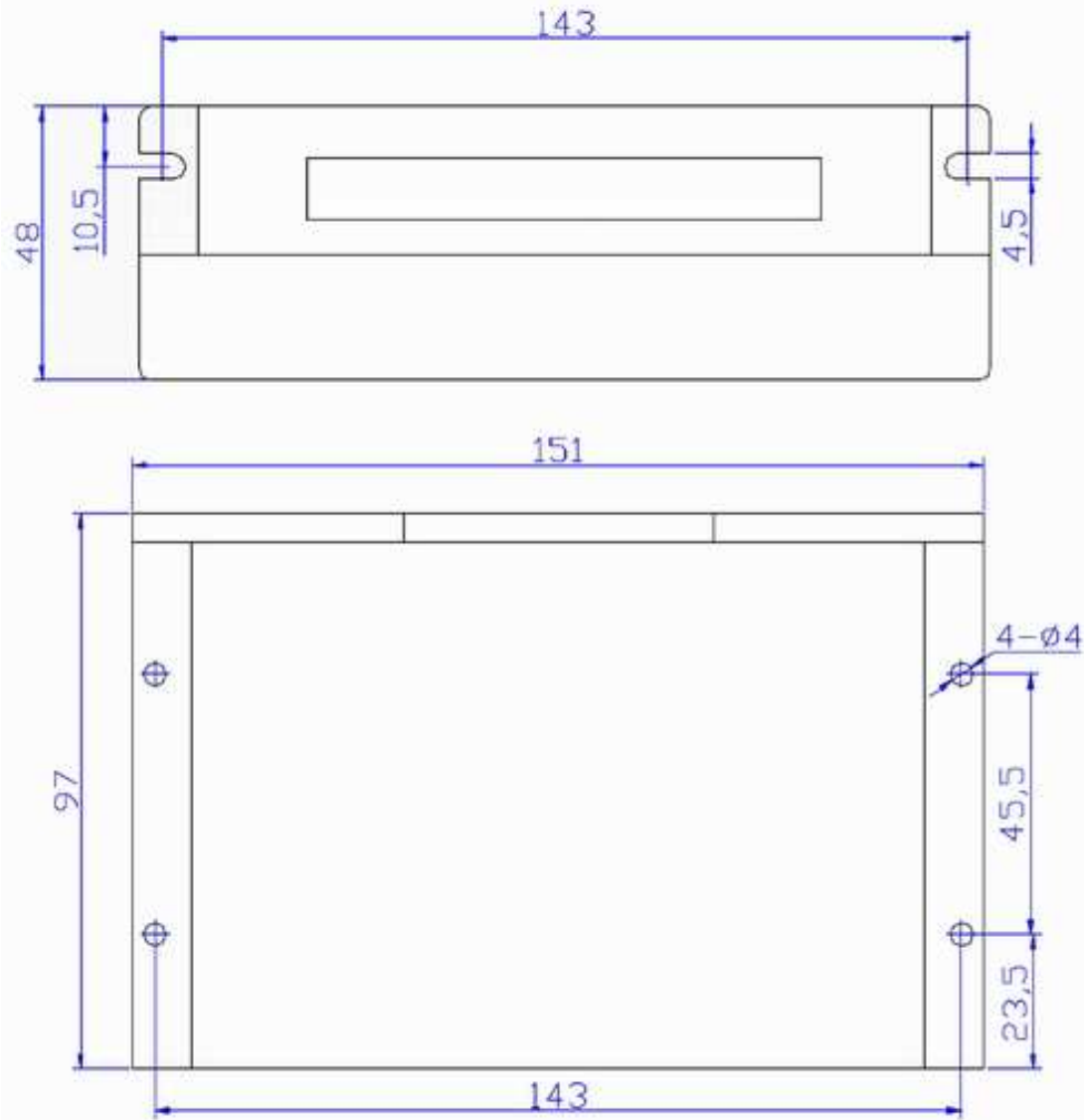

Figure 1: Mechanical Specifications

Pin Assignment and Description

Control Signal Connector P1 pins

Pin Function	Details
PUL+(+5V)	Pulse signal: In single pulse (pulse/direction) mode, this input represents pulse signal, effective for each rising or falling edge (set by inside jumper J1); 4-5V when PUL-HIGH, 0-0.5V when PUL-LOW. In double pulse mode (pulse/pulse), this input represents clockwise (CW) pulse, effective for high level or low level (set by inside jumper J1). For reliable response, pulse width should be longer than 1.2 μ s. Series connect resistors for current-limiting when +12V or +24V used.
PUL-(PUL)	
DIR+(+5V)	DIR signal: In single-pulse mode, this signal has low/high voltage levels, representing two directions of motor rotation; in double-pulse mode (set by inside jumper J2), this signal is counter-clock (CCW) pulse, effective for high level or low level (set by inside jumper J1). For reliable motion response, DIR signal should be ahead of PUL signal by 5 μ s at least. 4-5V when DIR-HIGH, 0-0.5V when DIR-LOW. Please note that motion direction is also related to motor-driver wiring match. Exchanging the connection of two wires for a coil to the driver will reverse motion direction.
DIR-(DIR)	
ENA+(+5V)	Enable signal: This signal is used for enabling/disabling the driver. High level (NPN control signal, PNP and Differential control signals are on the contrary, namely Low level for enabling.) for enabling the driver and low level for disabling the driver. Usually left UNCONNECTED (ENABLED) .
ENA-(ENA)	

Power connector P2 pins

Pin Function	Details
GND	DC power ground.
+V	DC power supply, 24~80VDC, Including voltage fluctuation and EMF voltage.
A+, A-	Motor Phase A
B+, B-	Motor Phase B

Microstep Resolution Selection

Microstep resolution is specified by 5, 6, 7,8 DIP switches as shown in the following table:

Microstep	Steps/rev.(for 1.8°motor)	SW5	SW6	SW7	SW8
2	400	ON	ON	ON	ON
4	800	OFF	ON	ON	ON
8	1600	OFF	OFF	ON	ON
16	3200	ON	OFF	ON	ON
32	6400	ON	ON	OFF	ON
64	12800	OFF	ON	OFF	ON
128	25600	OFF	OFF	OFF	ON
256	51200	ON	OFF	OFF	ON
5	1000	ON	ON	ON	OFF
10	2000	OFF	ON	ON	OFF
20	4000	OFF	OFF	ON	OFF
25	5000	ON	OFF	ON	OFF
40	8000	ON	ON	OFF	OFF
50	10000	OFF	ON	OFF	OFF
100	20000	ON	OFF	OFF	OFF
200	40000	OFF	OFF	OFF	OFF

Current Setting

Peak Current	SW1	SW2	SW3
2.8 A	ON	ON	ON
3.5 A	OFF	ON	ON
4.2 A	ON	OFF	ON
4.9 A	OFF	OFF	ON
5.7 A	ON	ON	OFF
6.4 A	OFF	ON	OFF
7.0 A	ON	OFF	OFF
7.8 A	OFF	OFF	OFF

Typical Connections

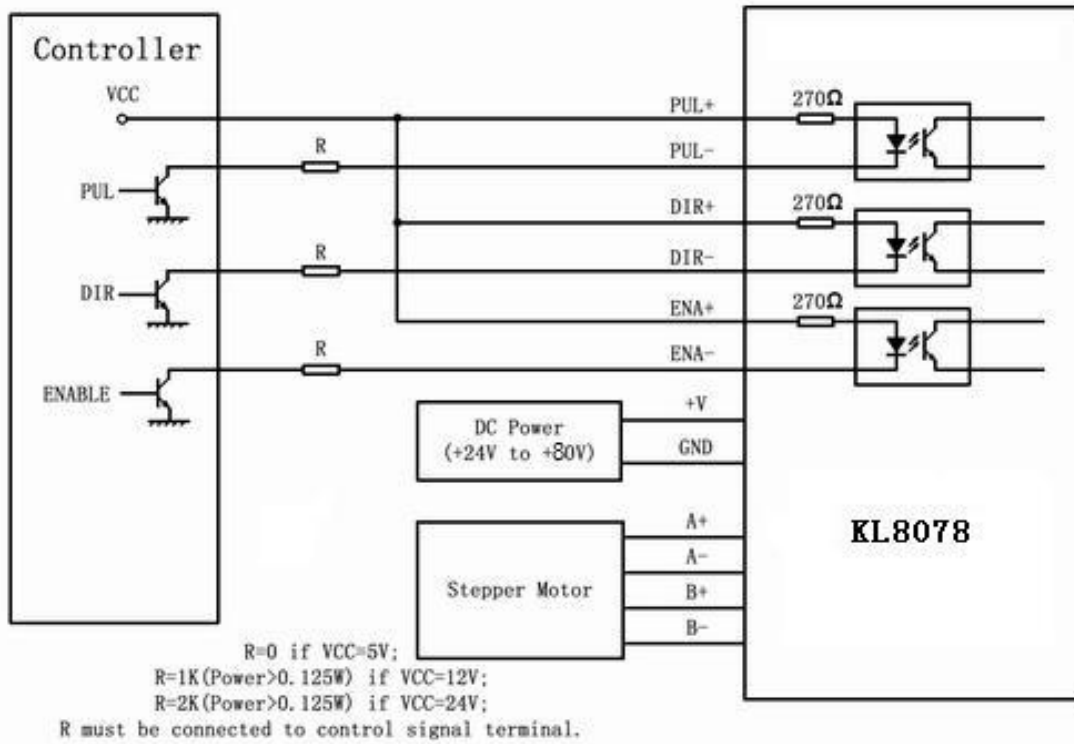

Figure 2: Typical Connections