

# Hybrid Stepper Motor

KL42H2150-42-8A

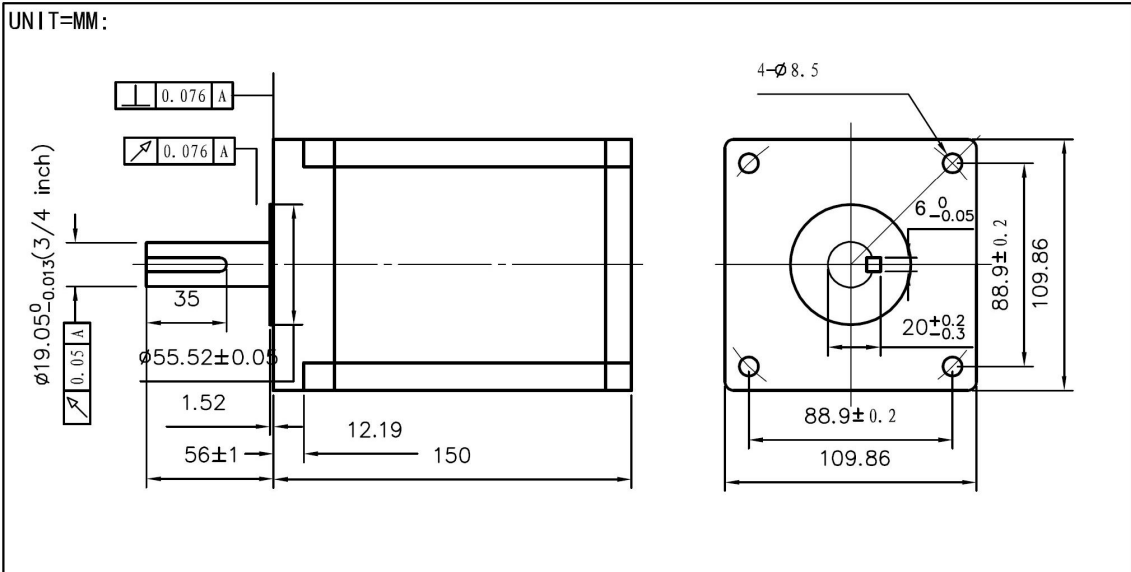

STEP ANGLE	CONNECTION STYLE	CURRENT	RESISTANCE	INDUCTANCE	HOLDING TORQUE	ROTOR INERTIA	WEIGHT
DEG/STEP		A	ohms	mH	OZ-IN	gcm <sup>2</sup>	Kg
1.8	Parallel	6	0.9	16	2830	10900	8.4
	Series	3	3.6	64			
	Unipolar	4.2	1.8	16	2100		

