

# Microstepping Driver

## KL5042

### Feature

- Patented technology
- Low cost, high torque under high speed condition
- Supply voltage up to +50VDC, peak current up to 4.2A
- 3-state current control technology
- Automatic idle-current reduction
- Suitable for 2-phase and 4-phase stepper motors
- Optically isolated input signals
- pulse frequency up to 400 KHz
- 15 selectable resolutions up to 25600 steps/rev
- DIP switch current setting with 8 different values
- PUL/DIR & CW/CCW mode optional
- Short-circuit, over-voltage, short-voltage protection
- Small size (118x75.5x33mm)

### Introduction

The KL5042 is an economical high performance microstepping driver based on one of the most advanced technologies in the world today. It is suitable for driving any 2-phase and 4-phase hybrid stepping motors. By using advanced bipolar constant-current chopping technique, it can output more speed and power from the same motor, compared with traditional technologies such as L/R drivers. Its 3-state current control technology allows coil currents to be well controlled, with relatively small current ripple and therefore less motor heating.

### Applications

Suitable for a wide range of stepping motors of Nema 17 and 23, and usable for various kinds of machines, such as X-Y tables, labeling machines, laser cutters, engraving machines, and pick-place devices. Extremely suitable for applications expected to be low vibration, high speed and high precision.

### Electronic Specifications (T<sub>j</sub>=25°C)

Parameters	KL5042			Unit
	Min	Typical	Max	
Output current	1.0	-	4.2 (3.0A RMS)	A
Supply voltage	20	36	50	VDC
Logic signal current	7	10	16	mA
Pulse input frequency	0	-	300	KHz
Isolation resistance	500			MΩ

## Mechanical Specifications (Unit: mm, 1 inch=25.4 mm)

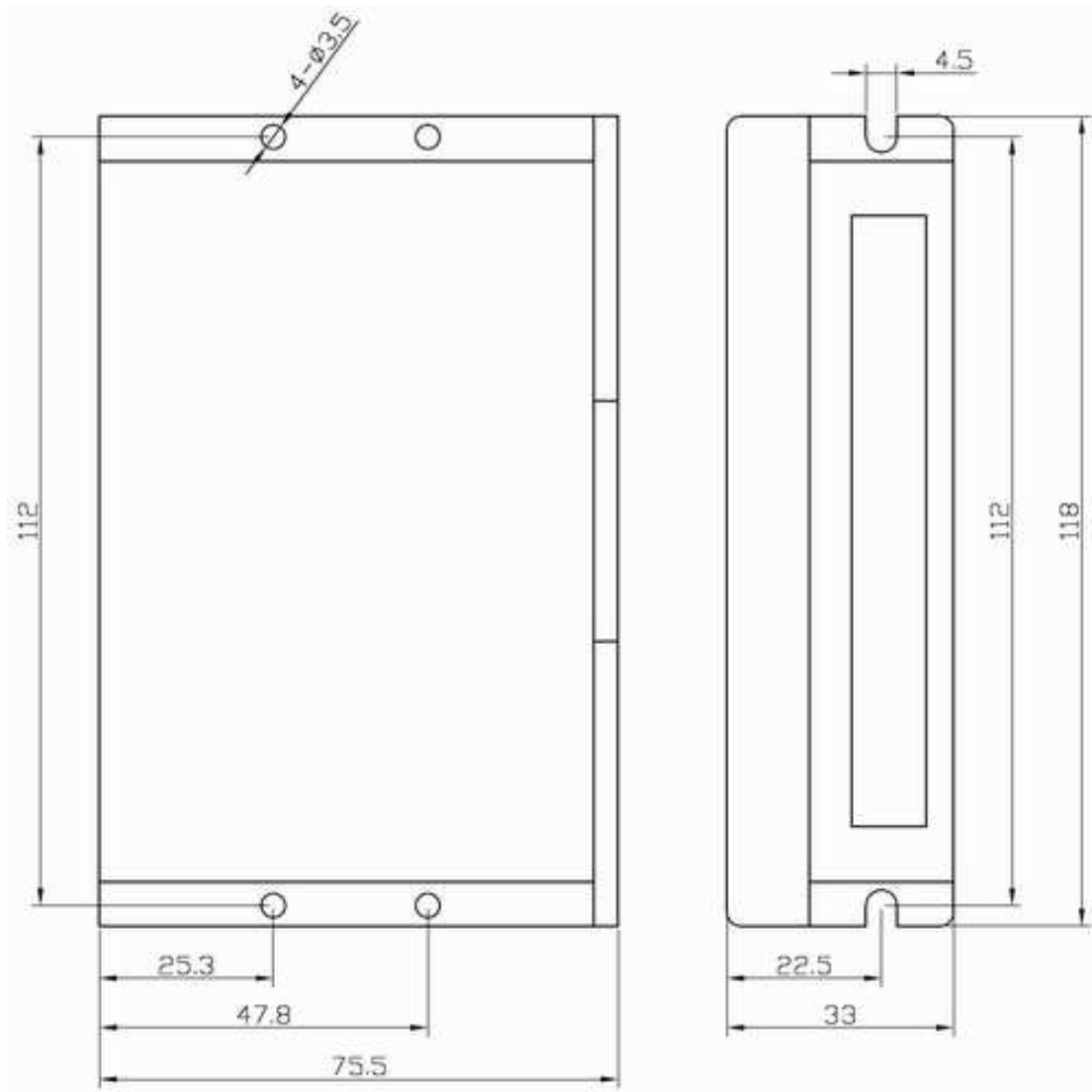

Figure 1: Mechanical Specifications

## Pin Assignment and Description

Control Signal Connector P1 pins

Pin Function	Details
PUL+(+5V)	<p><b>Pulse signal:</b> In single pulse (pulse/direction) mode, this input represents pulse signal, effective for each rising or falling edge (set by inside jumper J1); 4-5V when PUL-HIGH, 0-0.5V when PUL-LOW. In double pulse mode (pulse/pulse), this input represents clockwise (CW) pulse, effective for high level or low level (set by inside jumper J1). For reliable response, pulse width should be longer than 1.5<math>\mu</math>s. Series connect resistors for current-limiting when +12V or +24V used.</p>
PUL-(PUL)	
DIR+(+5V)	<p><b>DIR signal:</b> In single-pulse mode, this signal has low/high voltage levels, representing two directions of motor rotation; in double-pulse mode (set by inside jumper J3), this signal is counter-clock (CCW) pulse, effective for high level or low level (set by inside jumper J1). For reliable motion response, DIR signal should be ahead of PUL signal by 5<math>\mu</math>s at least. 4-5V when DIR-HIGH, 0-0.5V when DIR-LOW.</p>
DIR-(DIR)	
ENA+(+5V)	<p><b>Enable signal:</b> This signal is used for enabling/disabling the driver. High level (NPN control signal, PNP and Differential control signals are on the contrary, namely Low level for enabling.) for enabling the driver and low level for disabling the driver. Usually left UNCONNECTED (ENABLED).</p>
ENA-(ENA)	

## Power connector P2 pins

Pin Function	Details
GND	DC power ground
+V	DC power supply, 20~50VDC, Including voltage fluctuation and EMF voltage.
A+, A-	Motor Phase A
B+, B-	Motor Phase B

## Microstep Resolution Selection

Microstep resolution is specified by 5, 6, 7, 8 DIP switches as shown in the following table:

Microstep	Steps/rev.(for 1.8°motor)	SW5	SW6	SW7	SW8
2	400	OFF	ON	ON	ON
4	800	ON	OFF	ON	ON
8	1600	OFF	OFF	ON	ON
16	3200	ON	ON	OFF	ON
32	6400	OFF	ON	OFF	ON
64	12800	ON	OFF	OFF	ON
128	25600	OFF	OFF	OFF	ON
5	1000	ON	ON	ON	OFF
10	2000	OFF	ON	ON	OFF
20	4000	ON	OFF	ON	OFF
25	5000	OFF	OFF	ON	OFF
40	8000	ON	ON	OFF	OFF
50	10000	OFF	ON	OFF	OFF
100	20000	ON	OFF	OFF	OFF
125	25000	OFF	OFF	OFF	OFF

## Current Setting

Peak current (A)	RMS (A)	SW1	SW2	SW3
1.00	0.71	ON	ON	ON
1.46	1.04	OFF	ON	ON
1.91	1.36	ON	OFF	ON
2.37	1.69	OFF	OFF	ON
2.84	2.03	ON	ON	OFF
3.31	2.36	OFF	ON	OFF
3.76	2.69	ON	OFF	OFF
4.20	3.00	OFF	OFF	OFF

**Notes:** Due to motor inductance, the actual current in the coil may be smaller than the dynamic current setting, particularly under high speed condition.

## Typical Connections

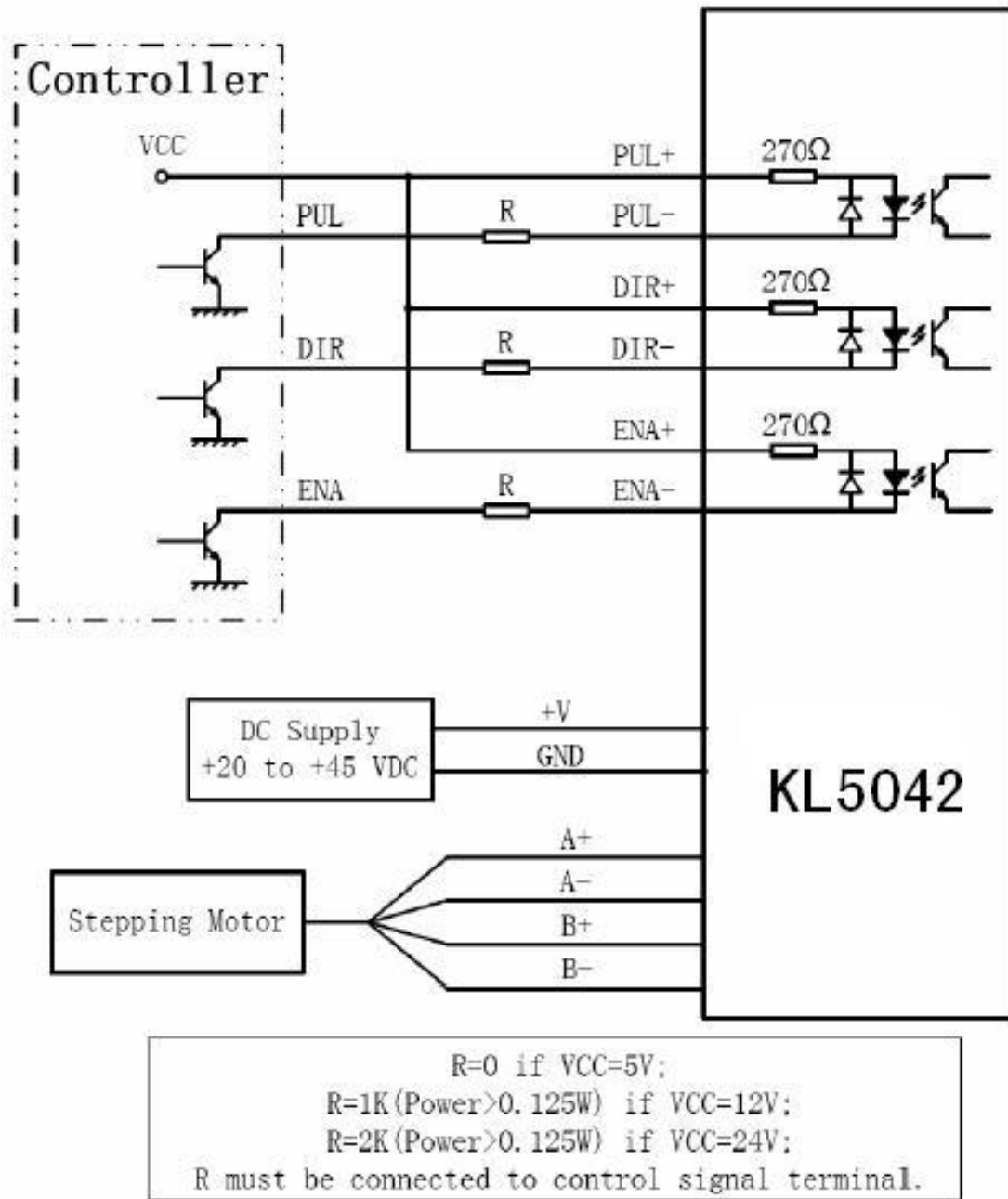

Figure 2: Typical Connections