

# Mach3 motion card wiring diagram

The input port can be connected to a mechanical switch or a photoelectric switch NPN type (connected to the PNP type photoelectric switch needs to be connected to a relay), the input signal is active low, minimum current 5mA

Frequency converter:  
0-10V Analog voltage speed regulation  
PWM 5V speed regulation

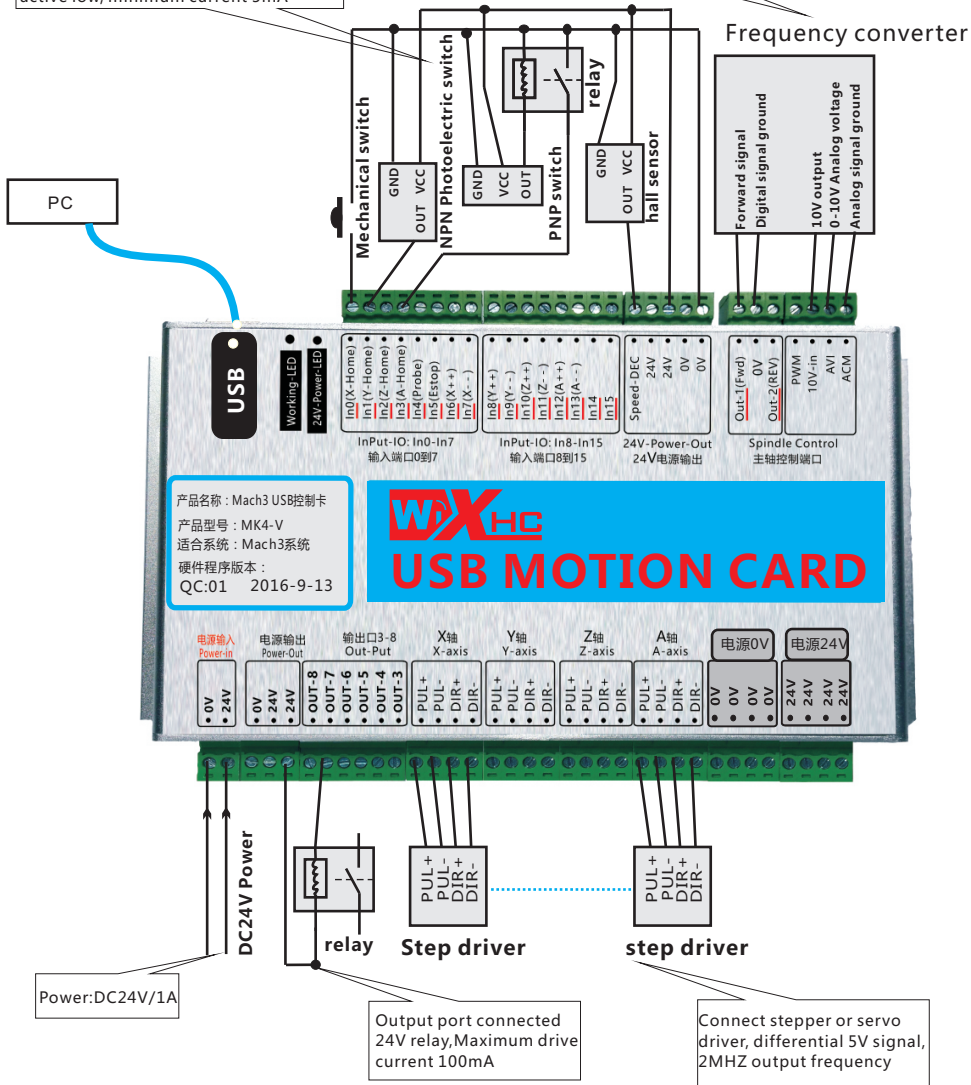

Power:DC24V/1A

Output port connected 24V relay,Maximum drive current 100mA

Connect stepper or servo driver, differential 5V signal, 2MHZ output frequency

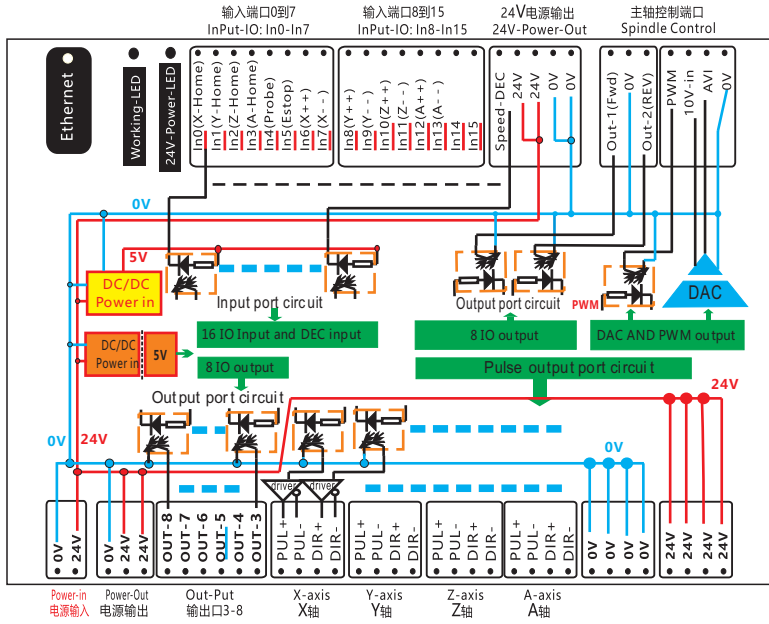

schematic diagram

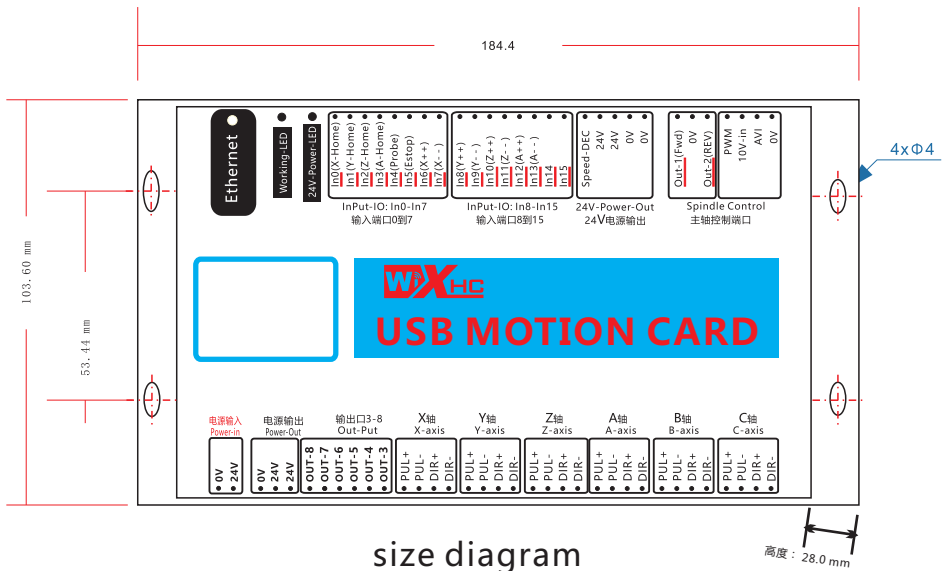

size diagram

# USB motion control card and driver wiring diagram

<—> Step driver wiring diagram

Control card

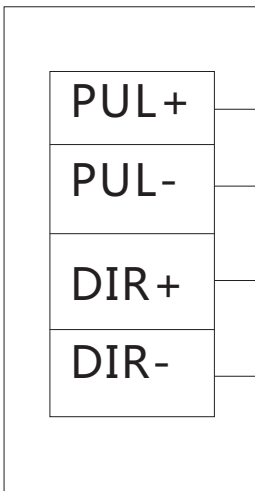

Step driver

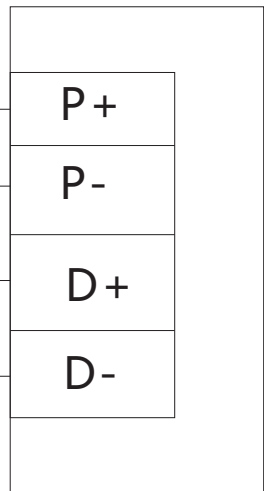

## <≡> WISE Servo driver

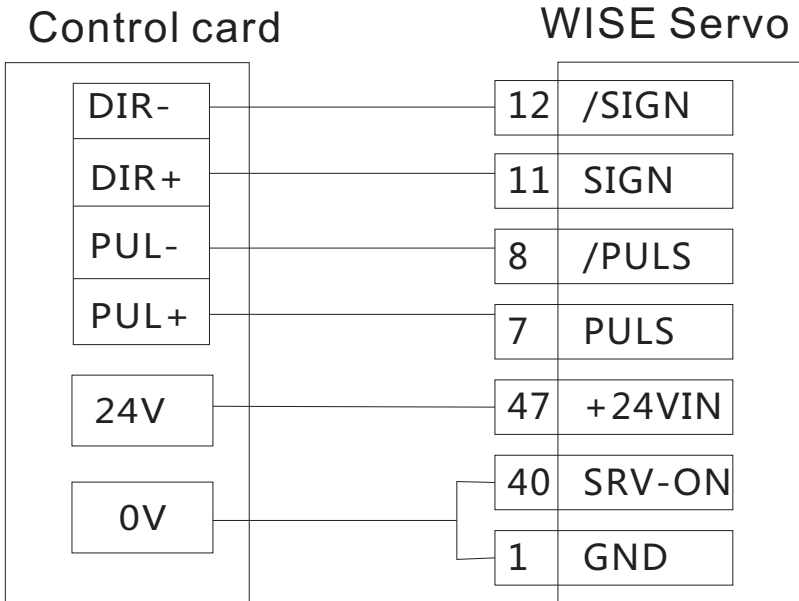

## <≡≡> Yaskawa servo driver

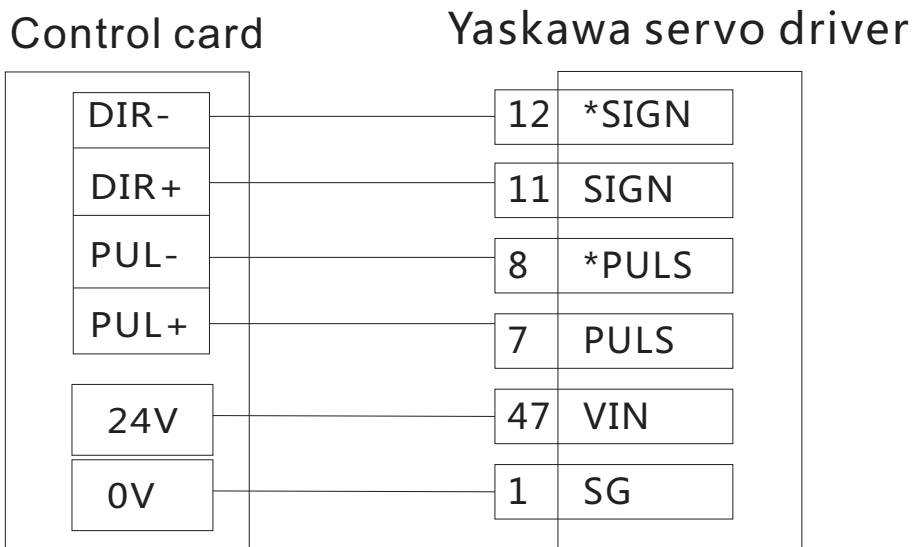

### <四> ASDA servo driver

Control card

ASDA-A servo driver

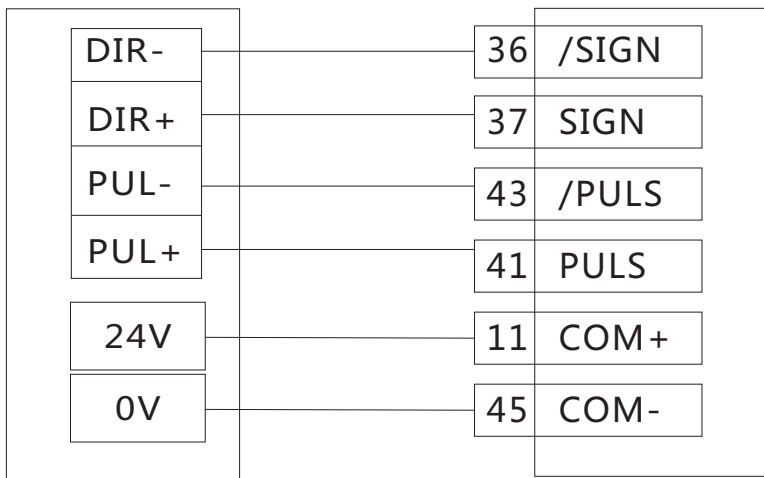

### <五> Panasonic MINAS A4 servo driver

Control card

MINAS A4 servo driver

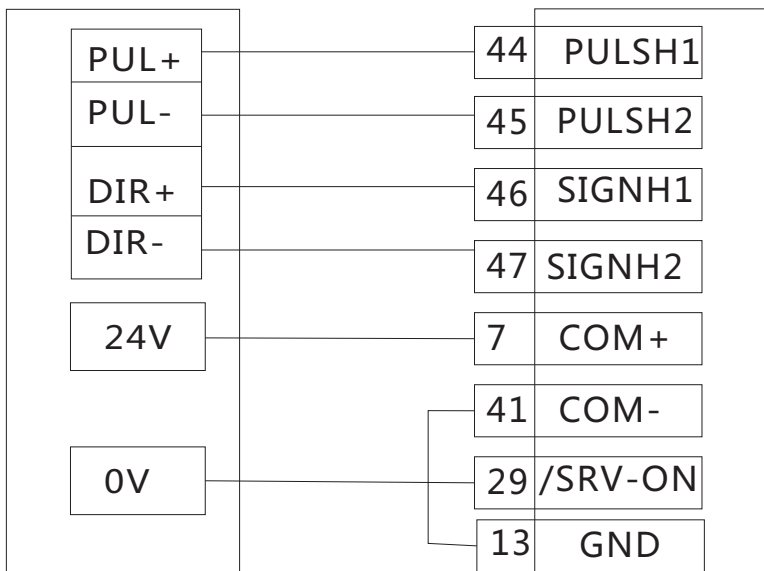

### <六> Mitsubishi MR-E servo driver

Control card

Mitsubishi servo driver

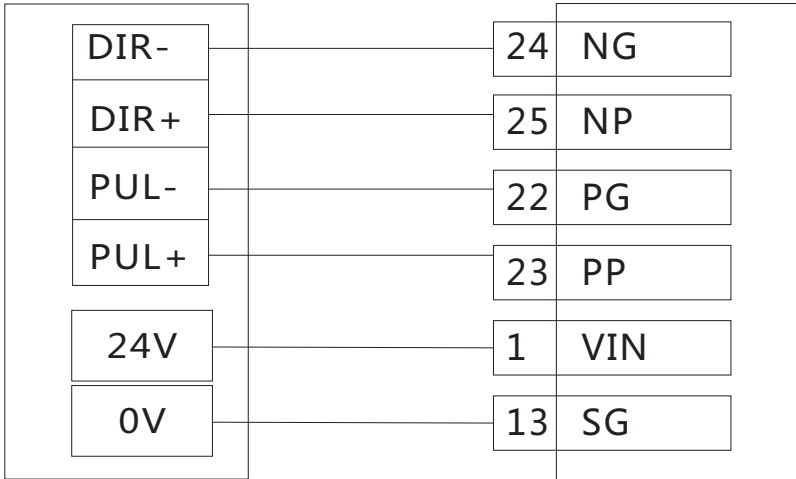

### <七> Fuji FALDIC servo driver

Control card

Fuji servo driver

