

Power: 0.3 Kw  
 Voltage: 75V  
 Current: 2-5 A  
 Rotating speed: 60000 r/min  
 Frequency: 1000 Hz  
 Weight: 1.5 KG

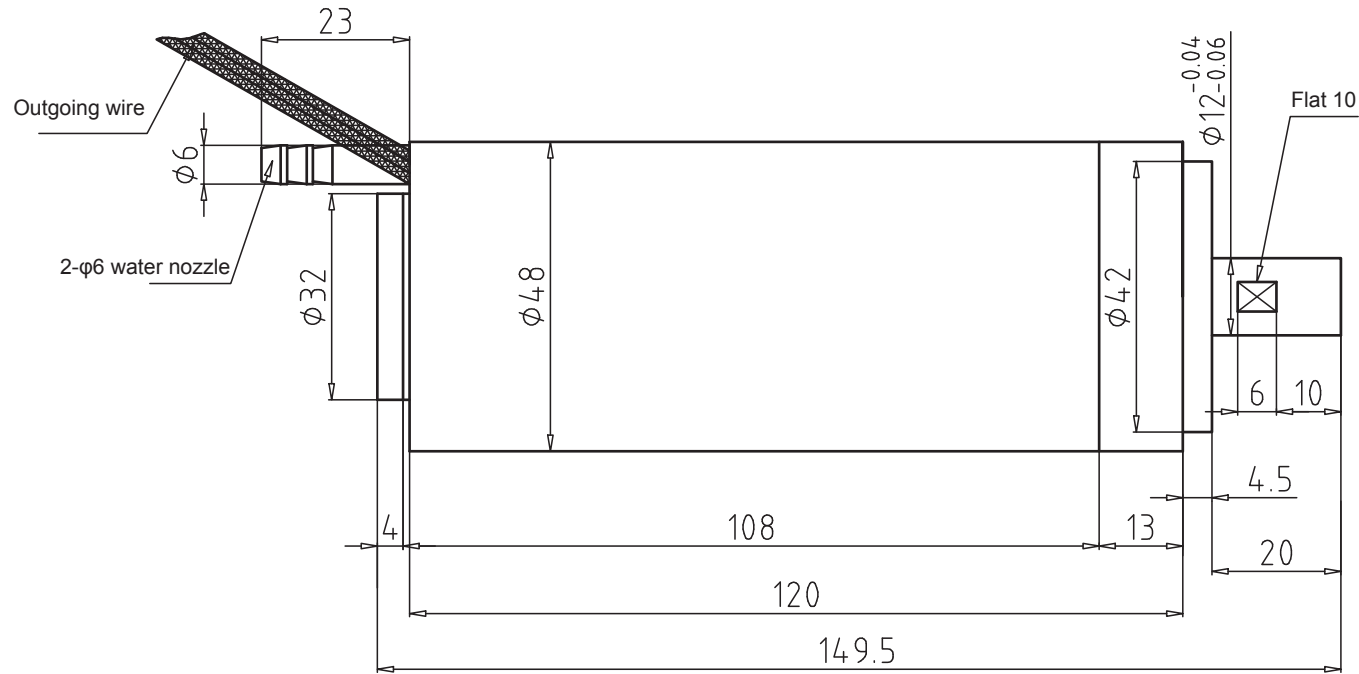

Be provided in the shaft extension end  
 1. Internal thread M6×0.75 carved small clamping chuck  
 2. External thread M12×0.75-ER8 nut

									<b>Outline diagram</b>
Marks	Number of places	Zoning	Modified document number	Signature	Date				<b>KL-300</b>
Designed by			Standardized by			Phase mark	Weight	Scale	
Reviewed by									
Processed by			Approved by			Total page(s)	Page		