

3.0 DESCRIPTION

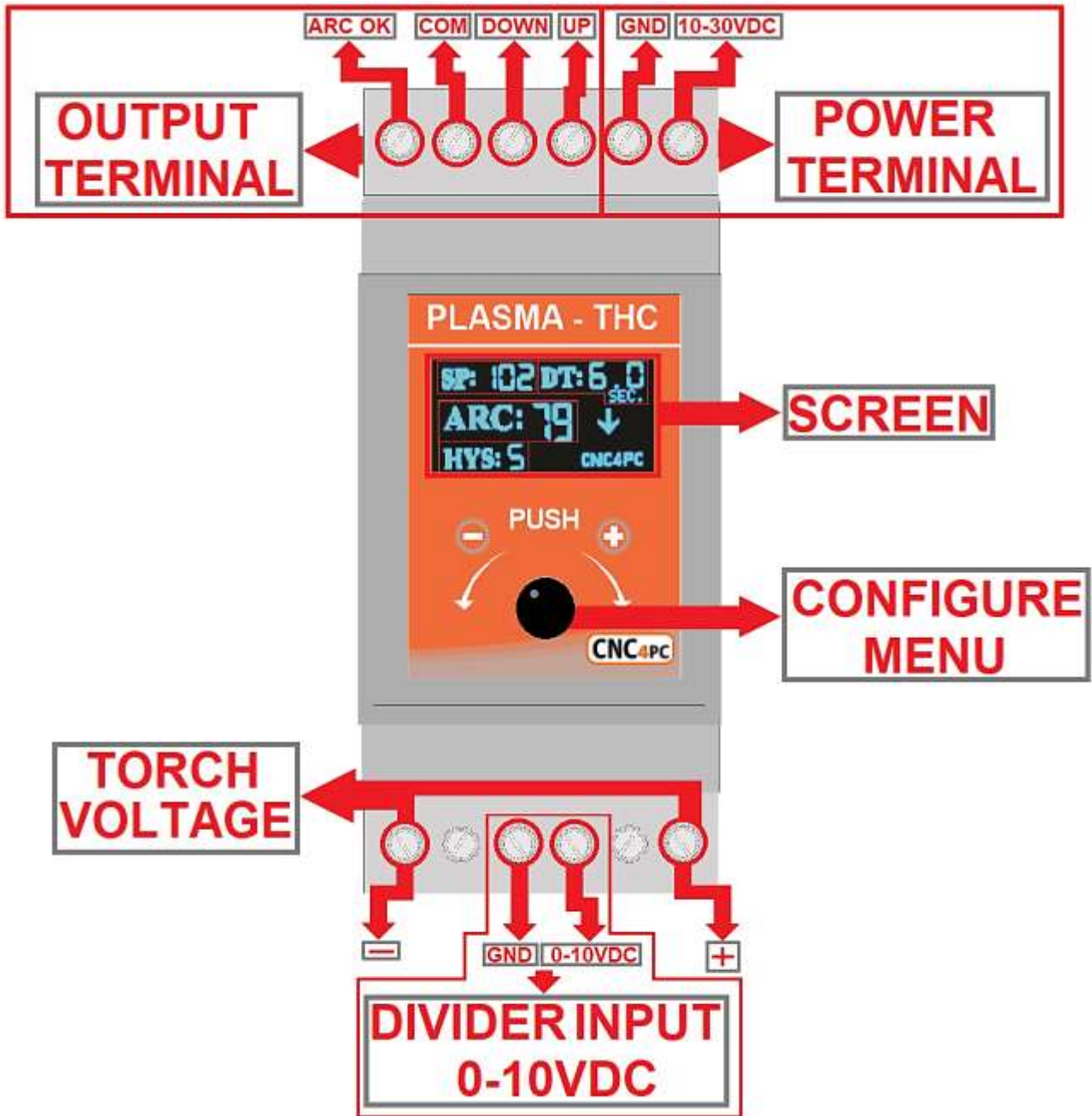

4.0 TERMINAL BOARD

4.1 POWER

Requires a 10 to 30VDC at 100mA Power Supply, "This board is electrically isolated through a DC-DC converter."

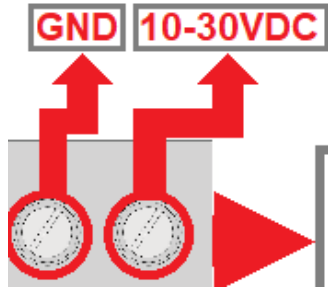

WARNING: Check the polarity and voltage of the external power source and connect the 10VDC to 30VDC and GND. Overvoltage or reverse-polarity power applied to these terminals can cause damage to the board, and/or the power source.

4.2 TORCH VOLTAGE

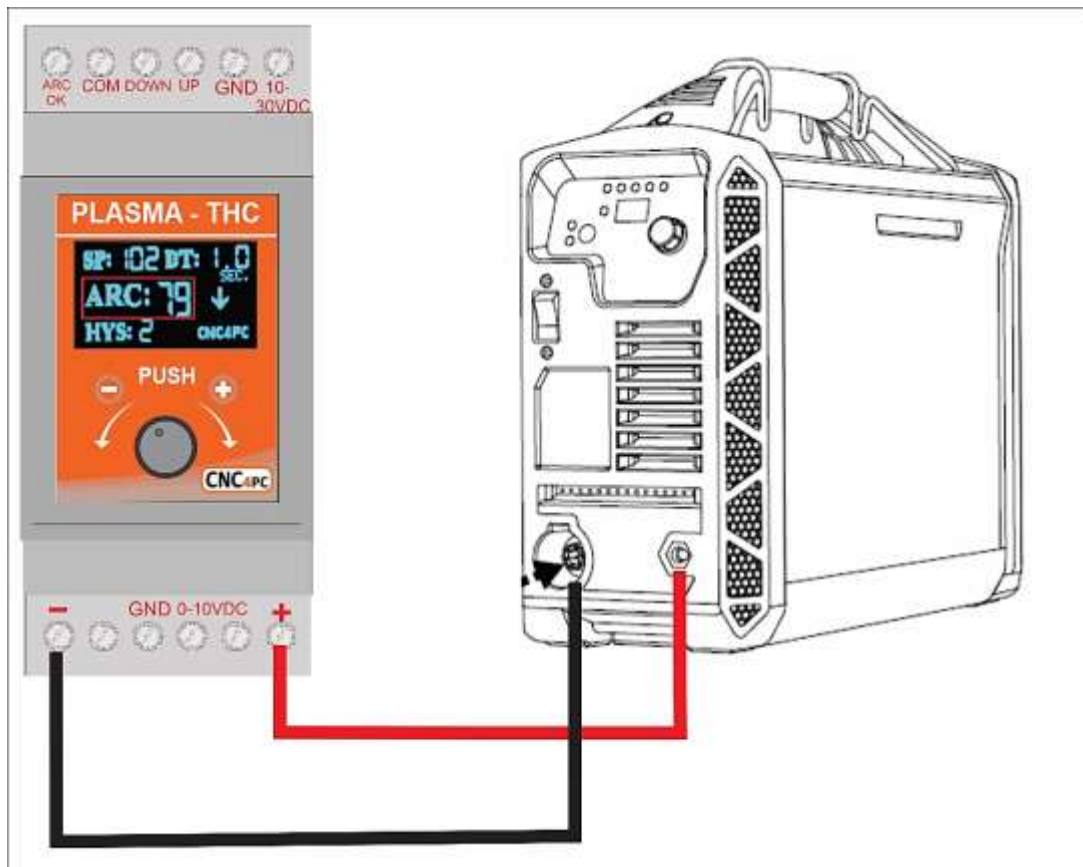

4.3 DIVIDER INPUT

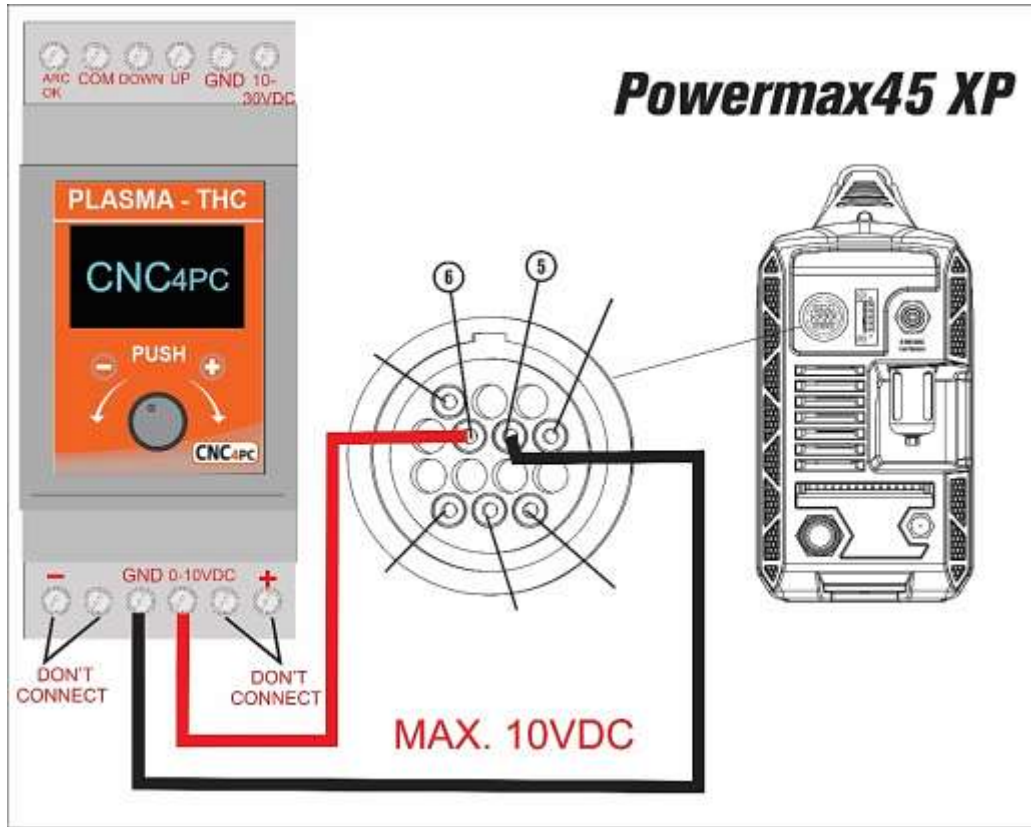

4.4 OUTPUT SIGNALS

Voltage applied can be from 5 to 80VDC@50mA, outputs signal optoisolated Open Collector.

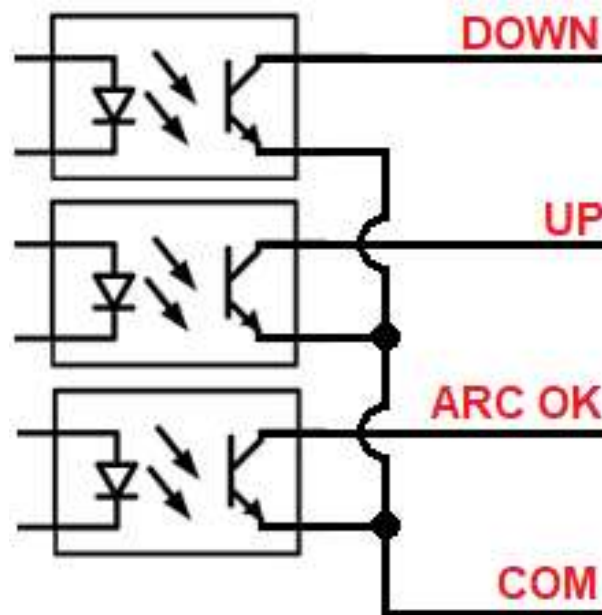

5.0 CONFIGURE MENU

Push

Turn knob



Push the knob to enter configuration mode.

Navigate through the configuration menu by pressing the knob.

Turn the knob to adjust the value.

Push the knob to set the value and navigate to the next parameter or until you reach the run mode.

6.0 DESCRIPTION SCREEN

6.1 SET POINT (SP)

SP is the target voltage to be achieved.



6.2 VOLTAGE ARC (ARC)

Limit from 40 to 400VDC, True Voltage measured at the terminals or the voltage divider.



6.3 HYSTERESIS (HYS)

Is the tolerance or (+/-) voltage range used to generate an adjustment. The torch height is not commanded to adjust if the true voltage is inside the specified range. It can be between 2 to 32VDC.



6.4 DELAY TIME (DT)

Torch motion starts the number of seconds you set as DT after the ARC signal is determined. This can be a value between 0.1 to 9.9 seconds.



7.0 WAIRING SAMPLE

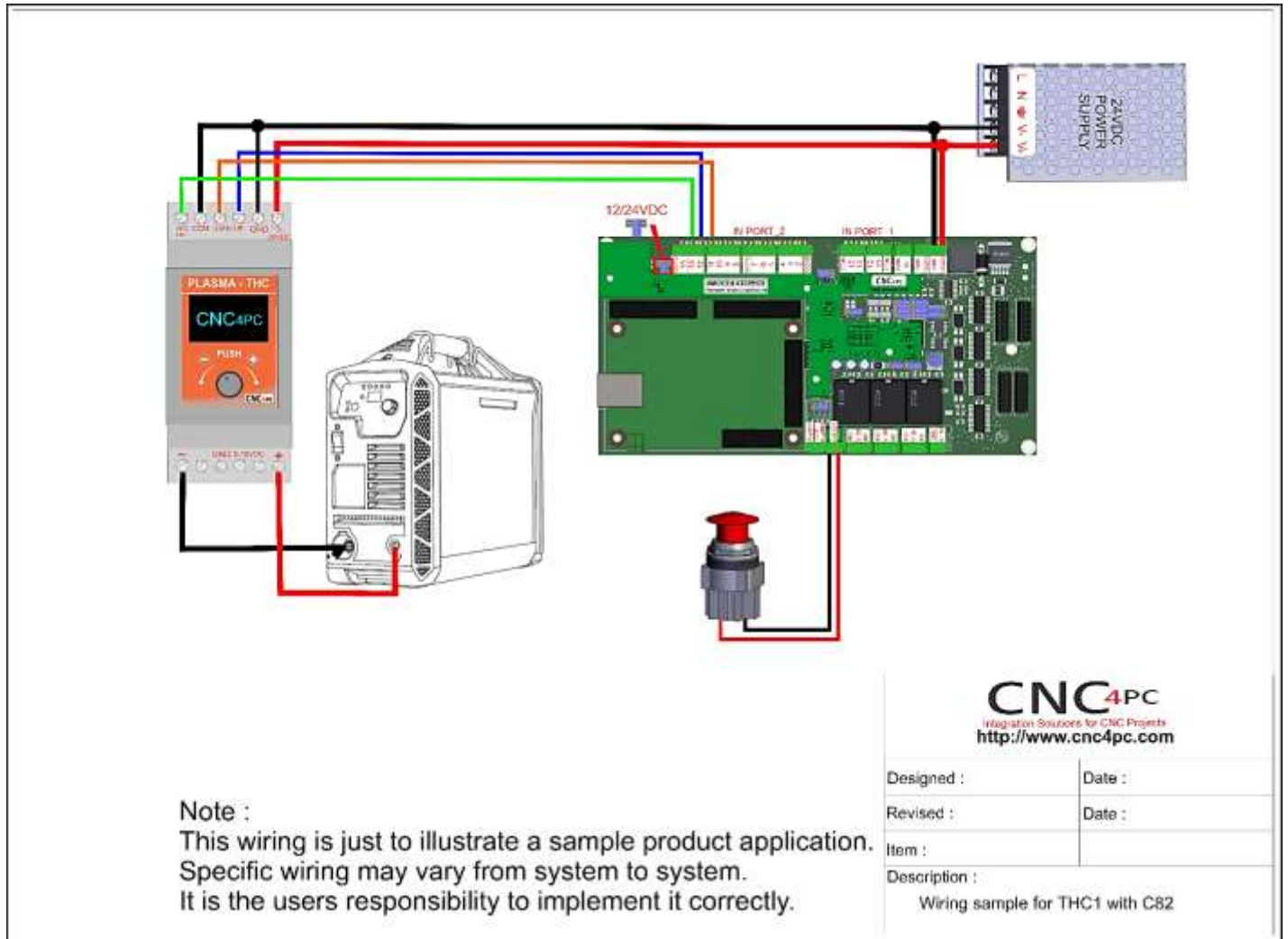

Note: [Open the Waring Sample here](#)

Disclaimer:

Use caution. CNC machines can be dangerous machines. Neither DUNCAN USA, LLC nor Arturo Duncan are liable for any accidents resulting from the improper use of these devices. This product is not a fail-safe device and it should not be used in life support systems or in other devices where its failure or possible erratic operation could cause property damage, bodily injury or loss of life.