

1.5KW - 4KW Fiber Laser Wiring Diagram

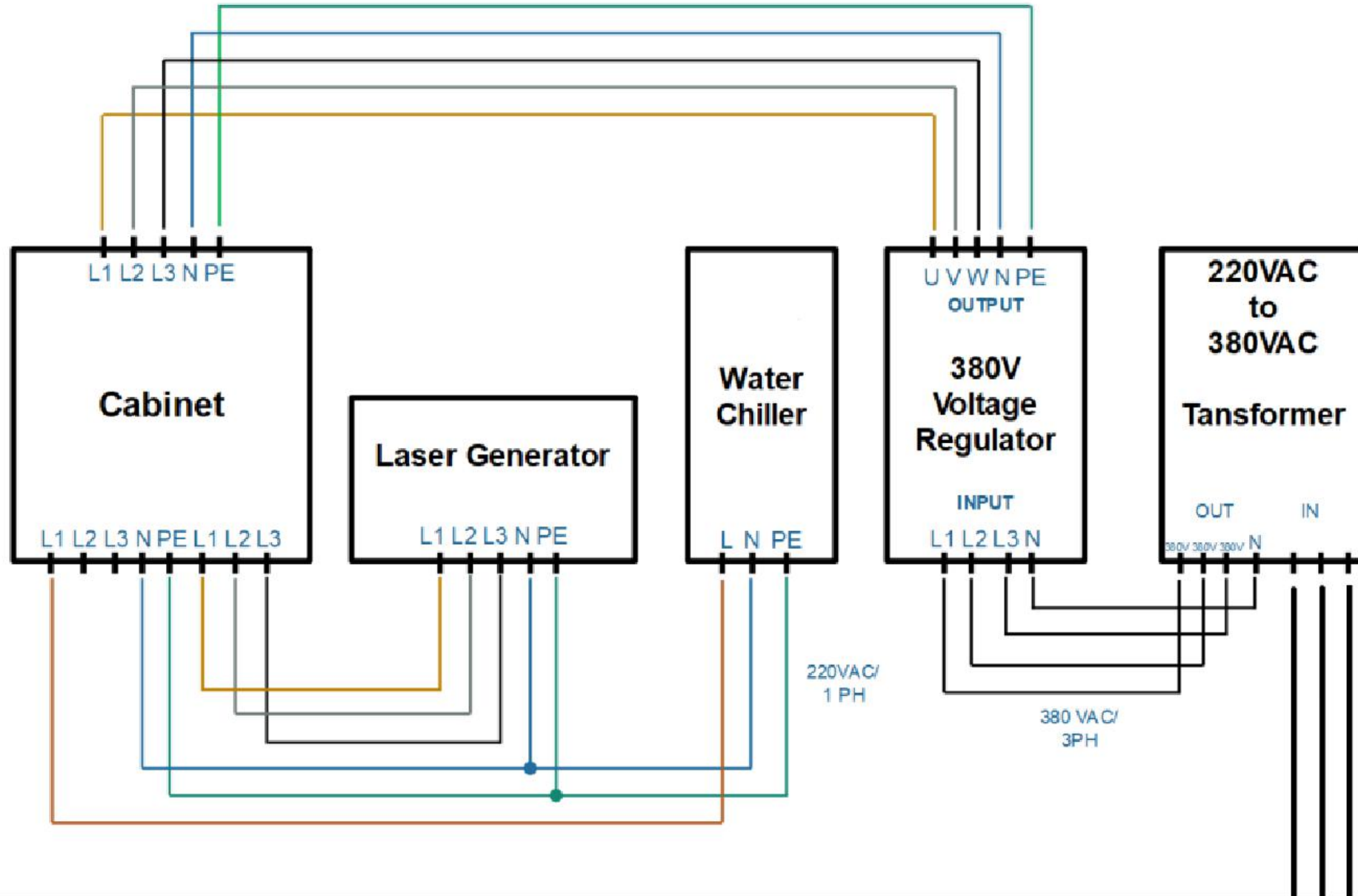

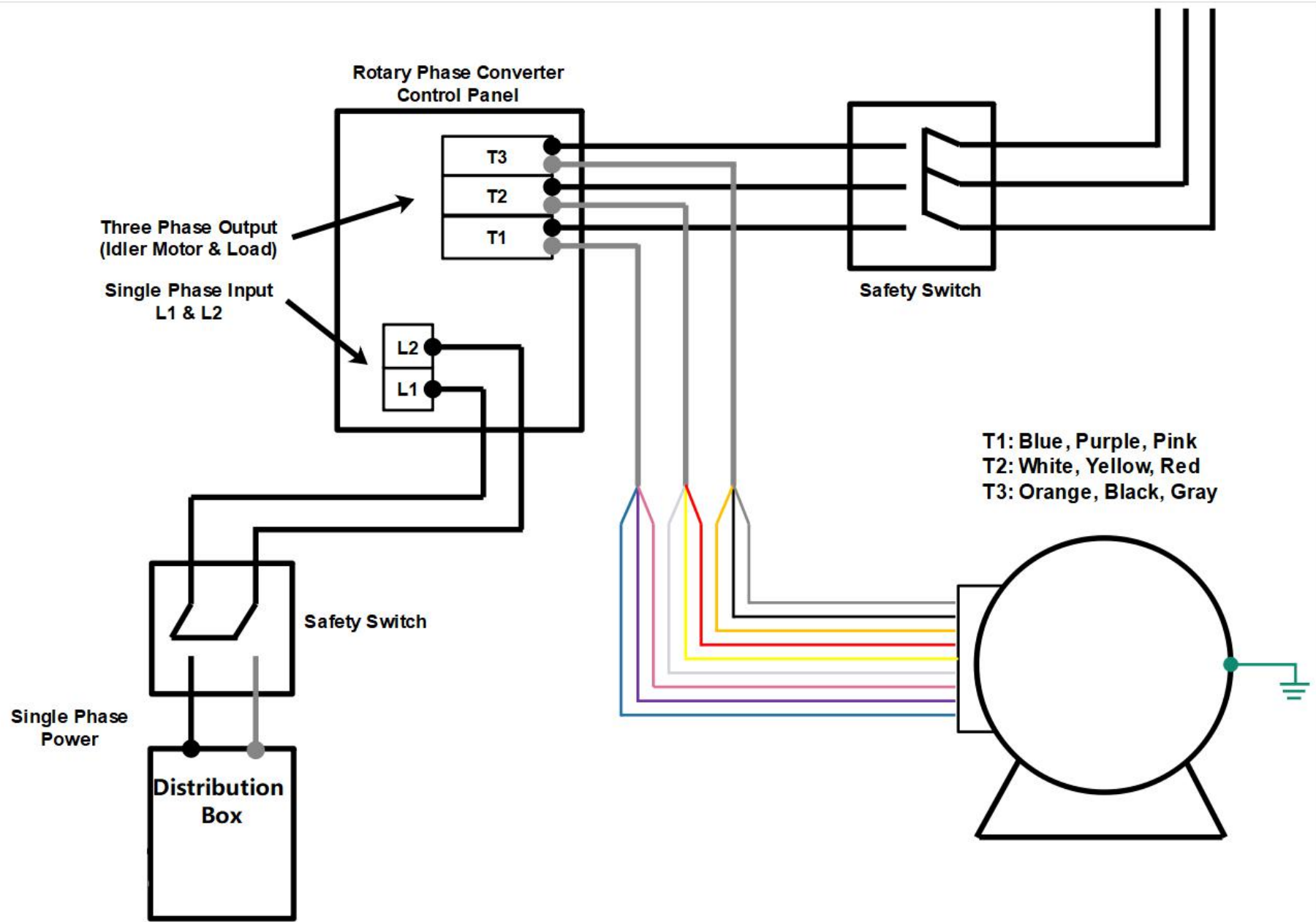

Branch Circuit and Wire Sizing

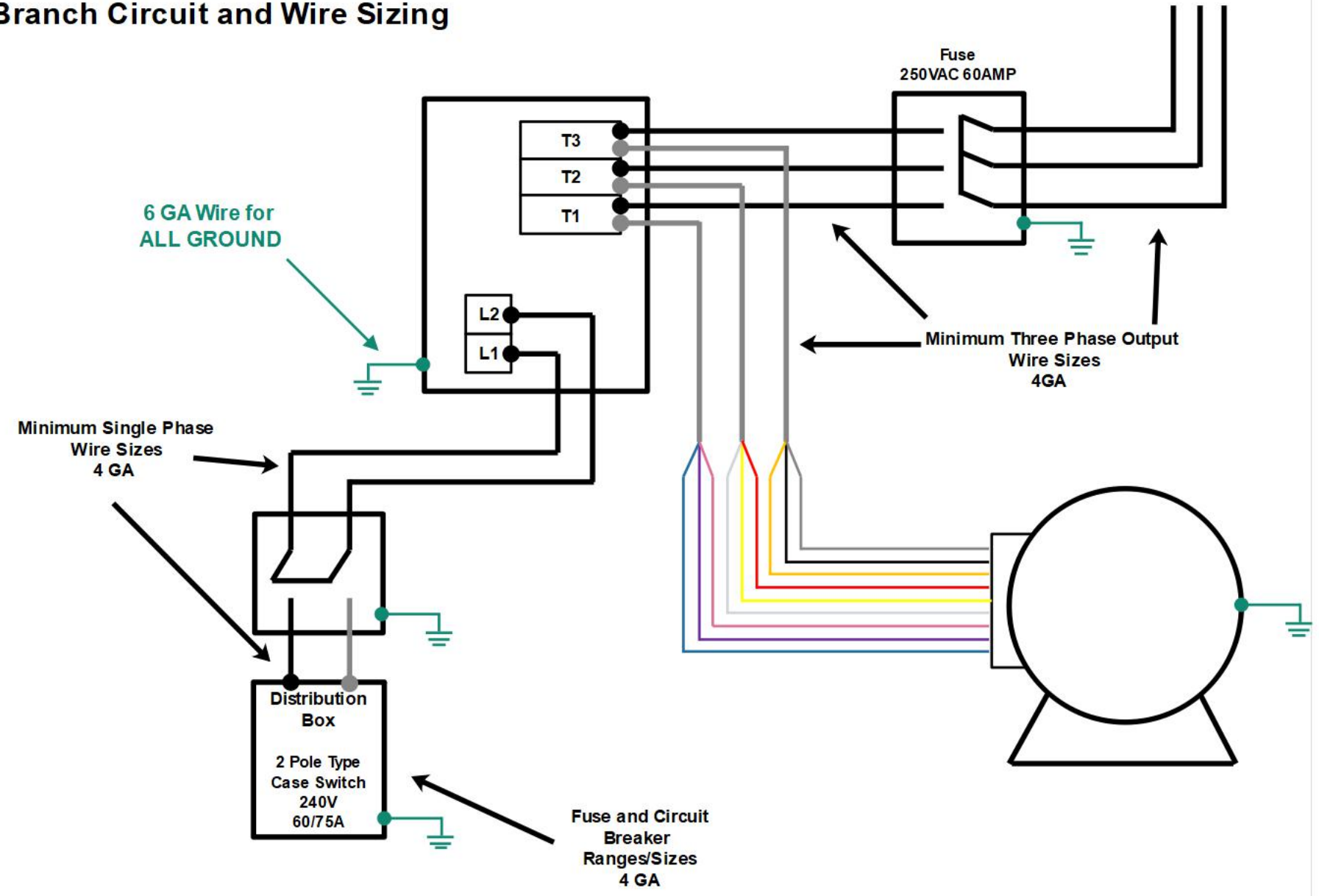

Branch Circuit and Wire Sizing

Column	A	B	C	D
Phase Converter HP	Minimum Circuit Breaker & Fuse Size	Maximum Circuit Breaker & Fuse Size	Minimum Single Phase Wire Sizes	Minimum Three Phase Wire Sizes
3	10 amps	20 amps	12	12
5	20amps	30 amps	10	12
7.5	20 amps	40 amps	8	10
10	30 amps	50 amps	6	10
15	40 amps	80 amps	4	8
20	50 amps	100 amps	2	6
25	60 amps	125 amps	1/0	4
30	70 amps	150 amps	2/0	2
40	100 amps	200 amps	4/0	1
50	125 amps	250 amps	250 MCM	2/0
60	150 amps	300 amps	300 MCM	3/0
80	175 amps	325 amps	350 MCM	4/0
100	200 amps	350 amps	350 MCM	4/0