KL-6060D Closed Loop Stepping System

1. Introduction

Descriptions

KL-6060D is a new generation hybrid servo driver, it combines the advantage of the servo system and stepper system, the system acts as nothing more than a high pole servo motor, the classic stepper motor noises and resonances vanish. Because the position is controlled, the motor can also no longer lose any steps up to its maximum torque.

Features

- Closed-loop control, no longer lose any steps, up to its maximum torque;
- higher torque and higher speed;
- Fast response;
- Reduced motor heating and more efficient;
- Zero-speed stability;
- Smooth motion and super-low motor noise;
- No Tuning and always stable;
- Lower cost.

Applications

KL-6060D is a low-cost, high-performance servo systems, suitable for a variety of large-scale automated equipments and instruments, such as low-cost, low vibration, noise, high-precision, high-speed devices, And it is ideal for applications where the equipment uses a belt-drive mechanism or otherwise has low rigidity and you don't want it to vibrate when stopping.

Electrical Specifications

Parameter	Min	Typical	Max	Unit
Input Voltage(DC)	20	-	60	VDC
Output Current	0	-	6.0	A
Pulse Signal Frequency	0	-	200	KHZ
Logic Signal Current	7	10	16	MA

2. Microstep and Dir Setting

Steps/Revolution:

Step/Rev	SW1	SW2	SW3	SW4
Default	on	on	on	on
800	off	on	on	on
1600	on	off	on	on
3200	off	off	on	on
6400	on	on	off	on
12800	off	on	off	on
25600	on	off	off	on
51200	off	off	off	on
1000	on	on	on	off
2000	off	on	on	off
4000	on	off	on	off
5000	off	off	on	off
8000	on	on	off	off
10000	off	on	off	off
20000	on	off	off	off
40000	off	off	off	off

Motor Direction (SW5)

Motor Direction		
SW5	ON	OFF
Direction	CW	CCW

Alarm Output(SW6)

Reference Chapter 3 Stator Signal Connector.

3. Connectors and Pin Assignment

The KL-6060D has four connectors, connector for control signals connections, connector for stator signal connections, connector for encoder feedback and connector for power and motor connections.

Control signal Connector

Control Signal connector	
Name	Description
PUL+	Pulse signal positive
PUL-	Pulse signal negative
DIR+	Direction signal positive
DIR-	Direction signal negative
ENA+	Enable signal positive, usually left unconnected(enable)
ENA-	Enable signal negative, usually left unconnected(enable)

Stator Signal Connector

Stator Signal Connector		
Name	SW6 OFF	SW6 ON
ALM+	Alarm Signal: OC output, Normally open, positive	Alarm Signal: OC output, Normally closed, positive
ALM-	Alarm Signal: OC output, Normally open, negative	Alarm Signal: OC output, Normally closed, negative

Encoder Extension Cable Pin Out

Name	Color
EGND	White
VCC	Red
EA-	Blue
EA+	Black
EB-	Green
EB+	Yellow

Power and Motor Connector

Name	Description
A+	Motor Phase A+(Blue)
A-	Motor Phase A- (Yellow)
B+	Motor Phase B+ (Black)
B-	Motor Phase B- (Red)
ADC	Power supply, 20-60VDC
GND	ground

Control Signal Connector Interface

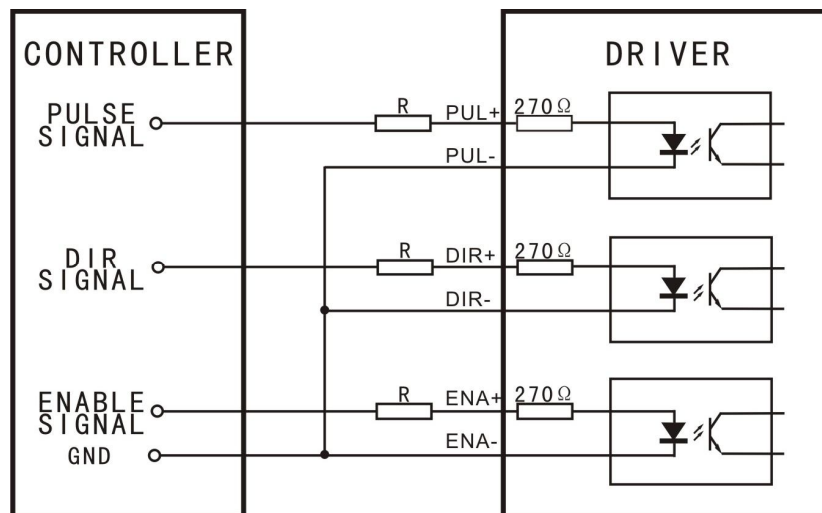

Figure1: Common-Cathode

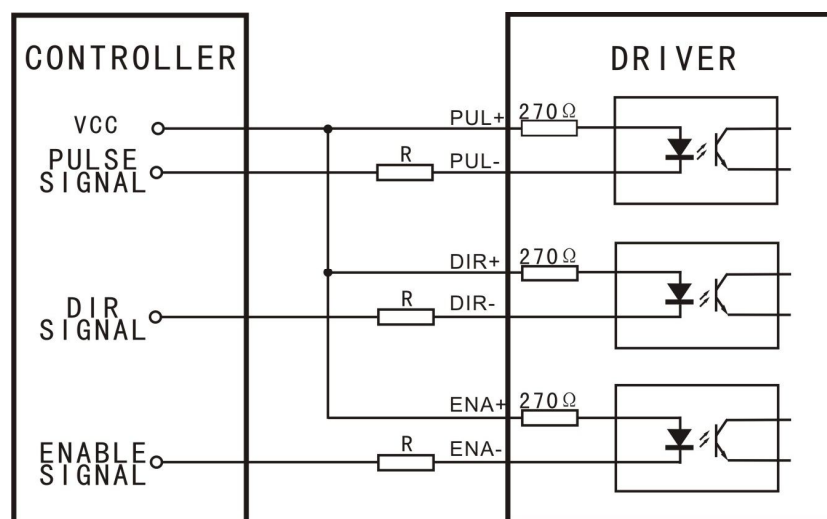

Figure2: Common-Anode

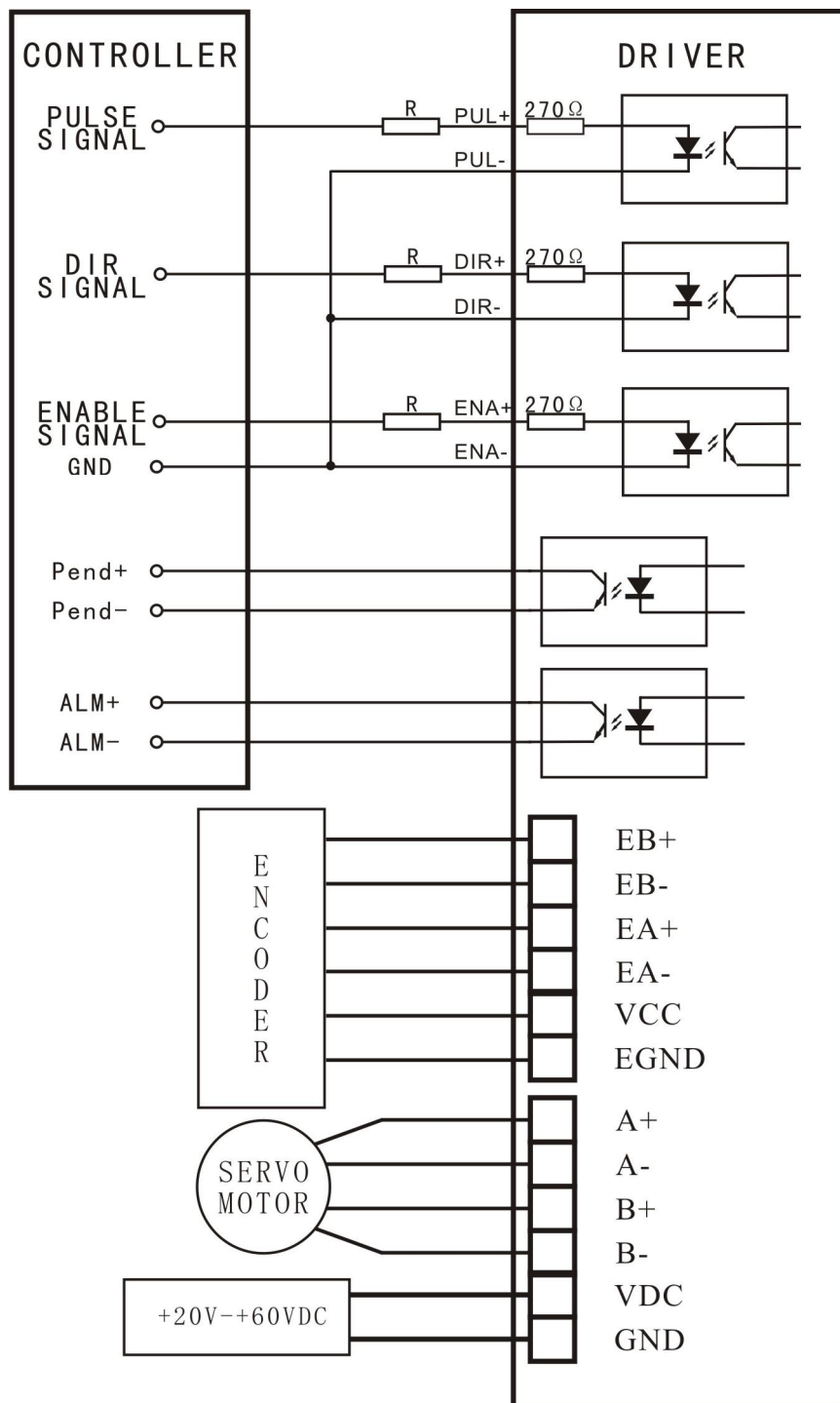

Figure 3: Typical Connection

VCC	R
5V	0
12V	680 Ω
24V	1.8K Ω

Table 1

4. Problems and Solutions

problems	Possible cause	solutions
Motor is not rotating	No power supply	Check the power supply
	No control signal	Check the control signal
	The driver is disabled	Don't connected the enable signal or enable the driver
ALM lights flashing	Supply voltage is too high or too low	Check the supply voltage
	Motor line wrong connect	Check the motor wiring
	Encoder line wrong connect	Check the encoder wiring
	Motor line short-circuit	Check motor lines eliminate the short-circuit
	Motor or drive failure	Replace the motor or drive
	Lose step	Restart driver
Motor rotates in the wrong direction	SW5 setting wrong	Change SW5 state
Inaccurate Position	The Micro steps set incorrectly.	Set the correct segments
	Control signal is interfered	Eliminate interference
Motor Stalled	Power supply voltage too low	Increasing the supply voltage
	Accelerating time is too short.	Extend the acceleration time

5. Mechanical Specifications (unit: mm(inch), 1 inch = 25.4mm)

