

# Hybrid Stepper Motor

KL34H2120-60-4B

UNIT=MM:

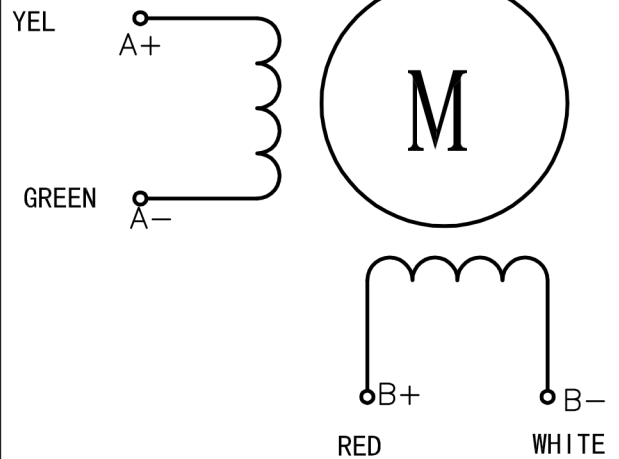
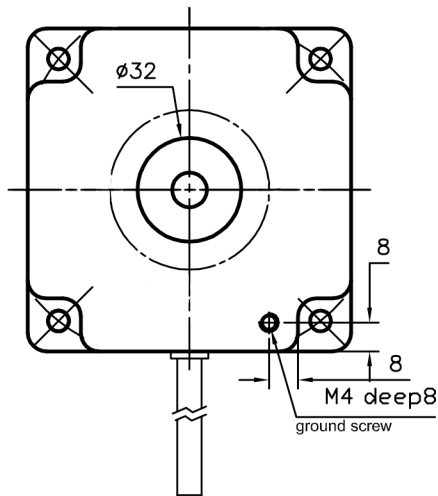
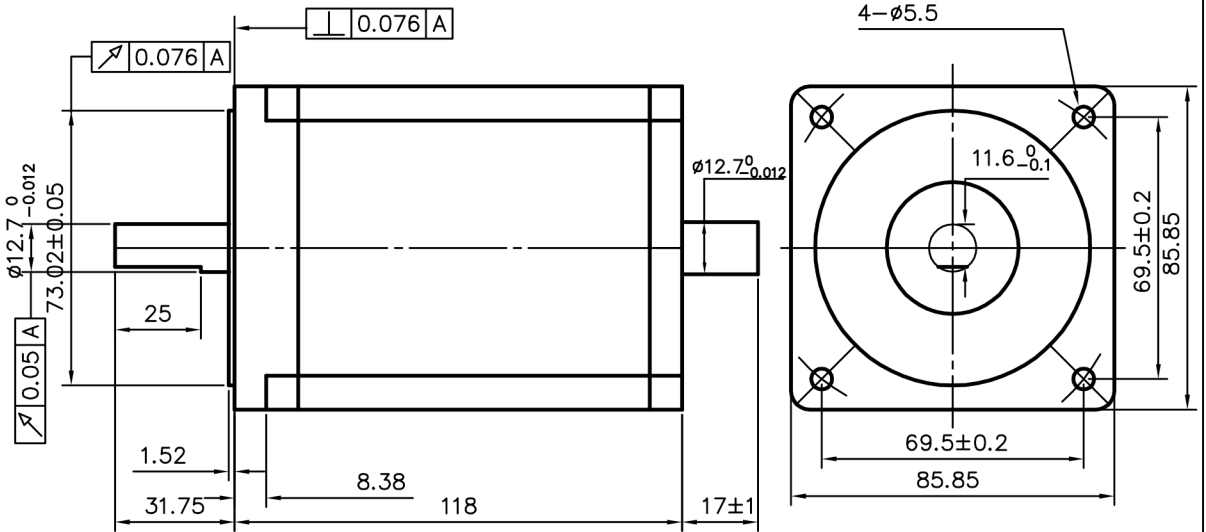

1430-AWG18#LENGTH310mm

PHASE	STEP ANGLE	CURRENT	RESISTANCE	INDUCTANCE	HOLDING TORQUE	ROTOR INERTIA	WEIGHT
	DEG/STEP	A	ohms	mH	OZ-IN	gcm <sup>2</sup>	Kg
2	1.8	6.0	0.5	6	1200	2700	3.8