

## **6 Axis Mach3 Breakout Board KL-DB25-6 With Relay and Spindle Control**

### **Requirements:**

1. [6 Axis Breakout Board KL-DB25-6](#)
2. [48V/12.5A Power Supply](#)
3. 24V with 5V Power Supply
4. [KL-5056, KL-8070D Stepper Motor Driver](#)
5. [NEMA23, NEMA34 Stepper Motor](#)
6. [220V 2.2KW VFD](#)
7. [2.2KW Spindle](#)

# Mach3 Breakout Board with Relay & Spindle Control

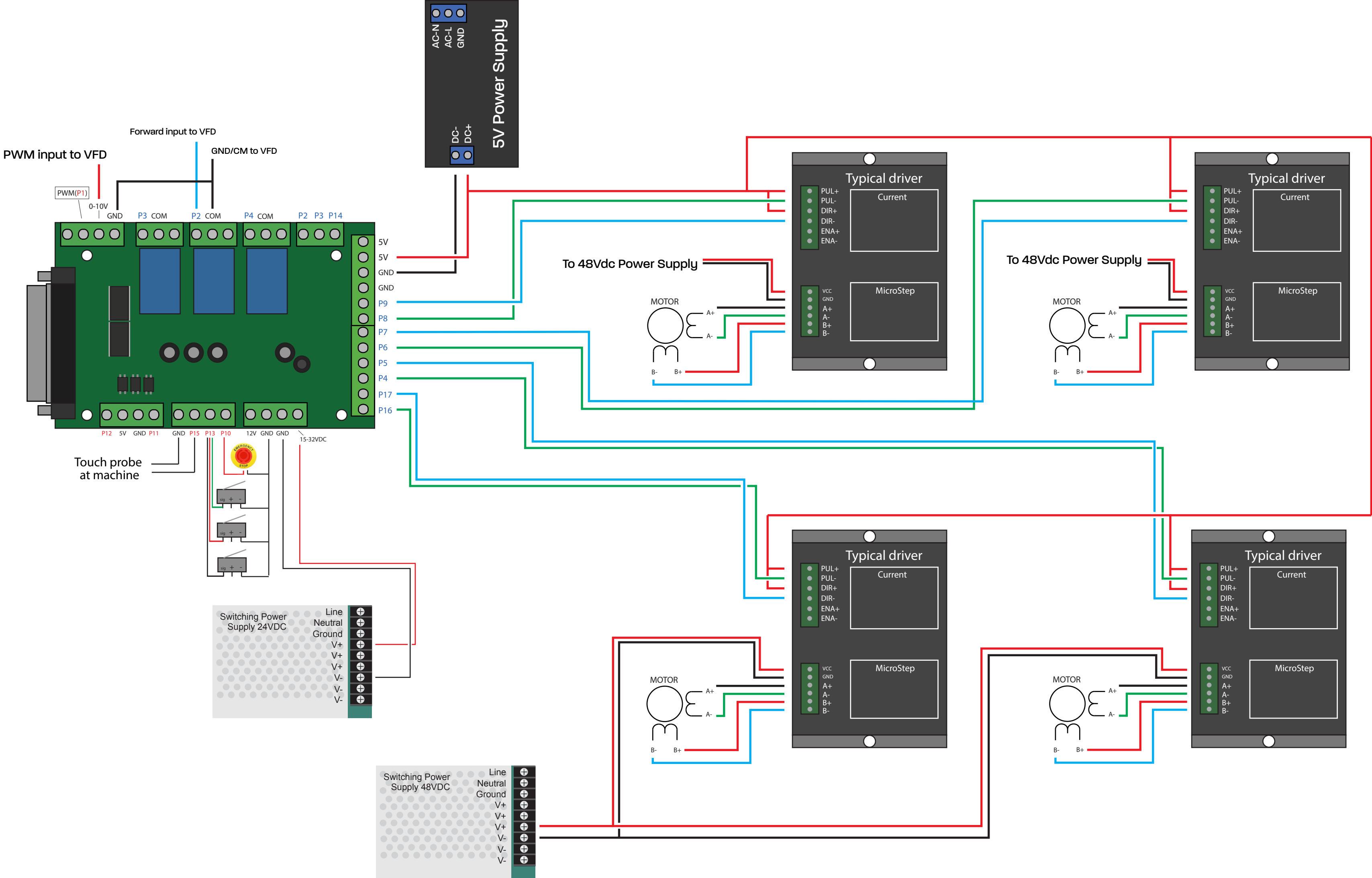

### Mach3 Setup

- Motor Outputs

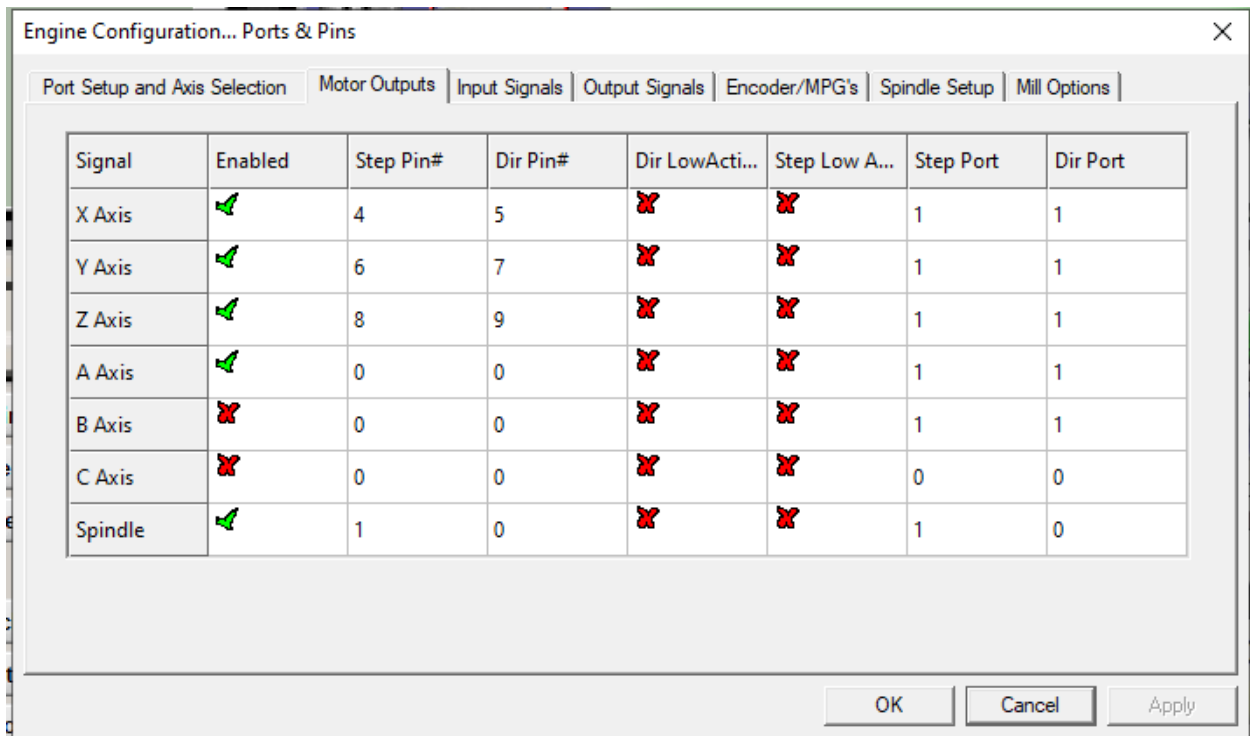

- Input Signals

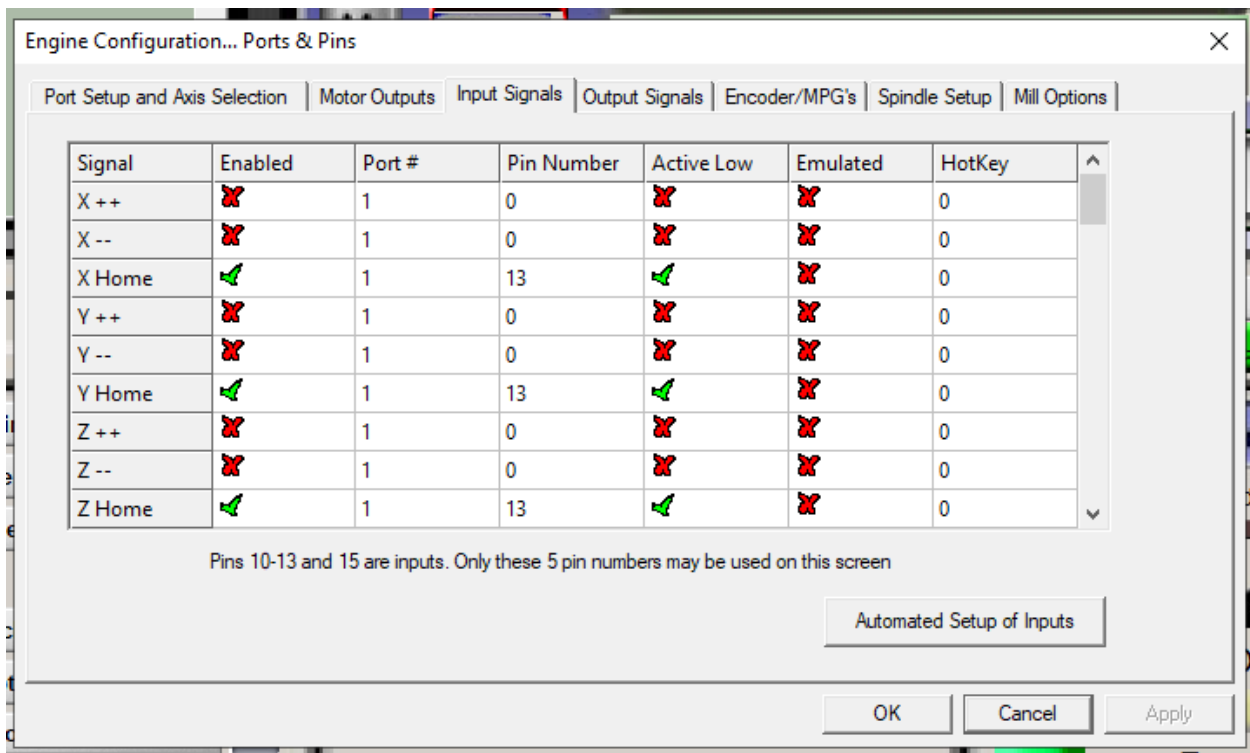

- Input Signals

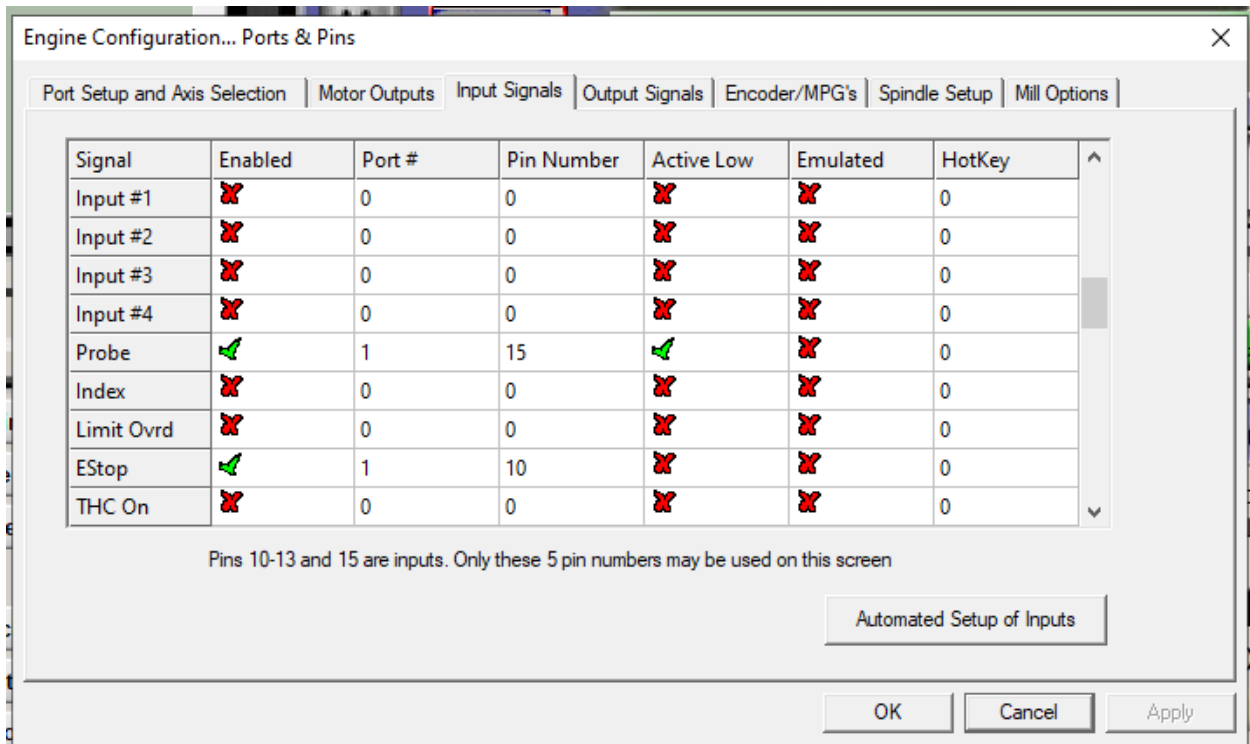

- Output Signals

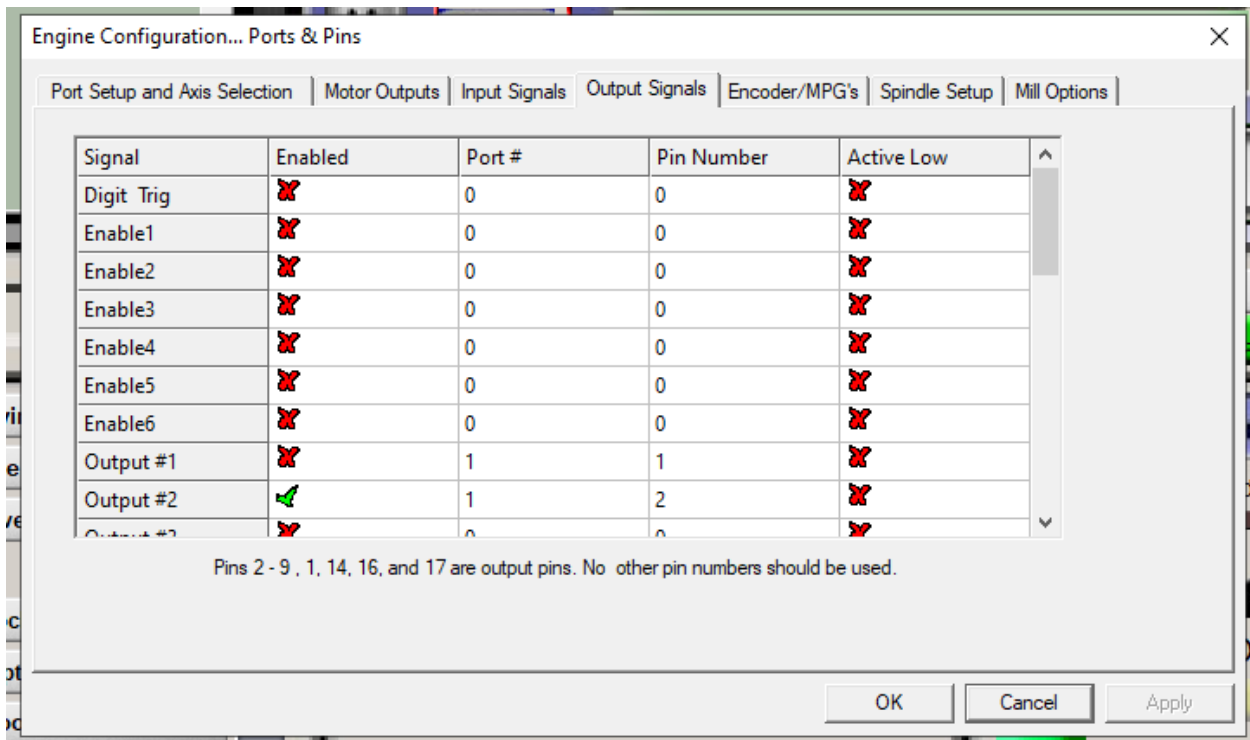

- Output Signals

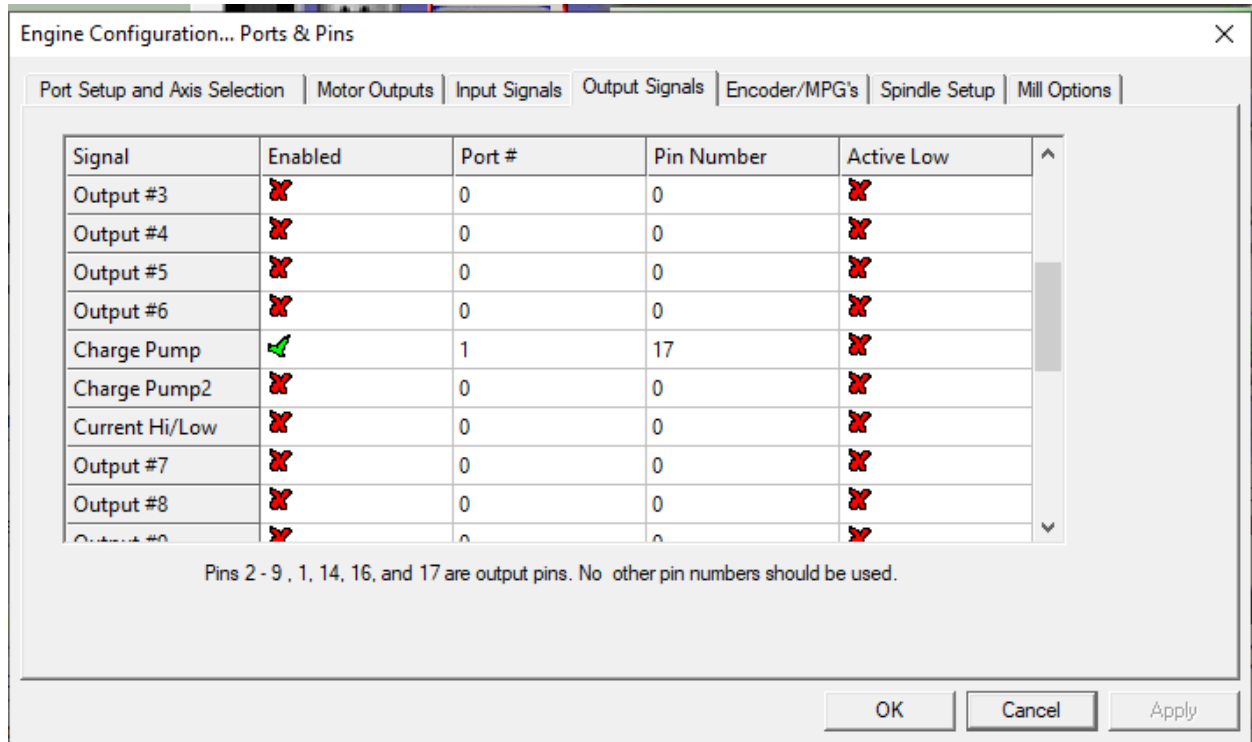

- Spindle Setup

